

Data Sheet

WÖHR PARKLIFT 450



Outdoor installation

- **Single units: 2 cars**
Double units: 4 cars
- **Platform load options**
(including snow load up to 20 cm):
 - **upper level:**
max. 1500 kg, load per wheel 375 kg
 - **lower level:**
max. 2000 kg, load per wheel 500 kg
 - **upper level:**
max. 2000 kg, load per wheel 500 kg
 - **lower level:**
max. 2600 kg, load per wheel 650 kg
- **Platform slopes for drive-on:**
 - upper level: 0,5° = 1% ascent
 - lower level: 0,5° = 1% ascent
 Platform slopes help drainage

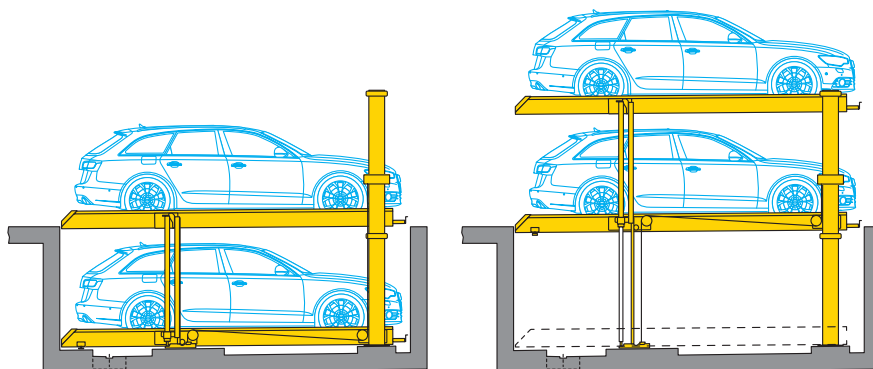

Length and height dimensions

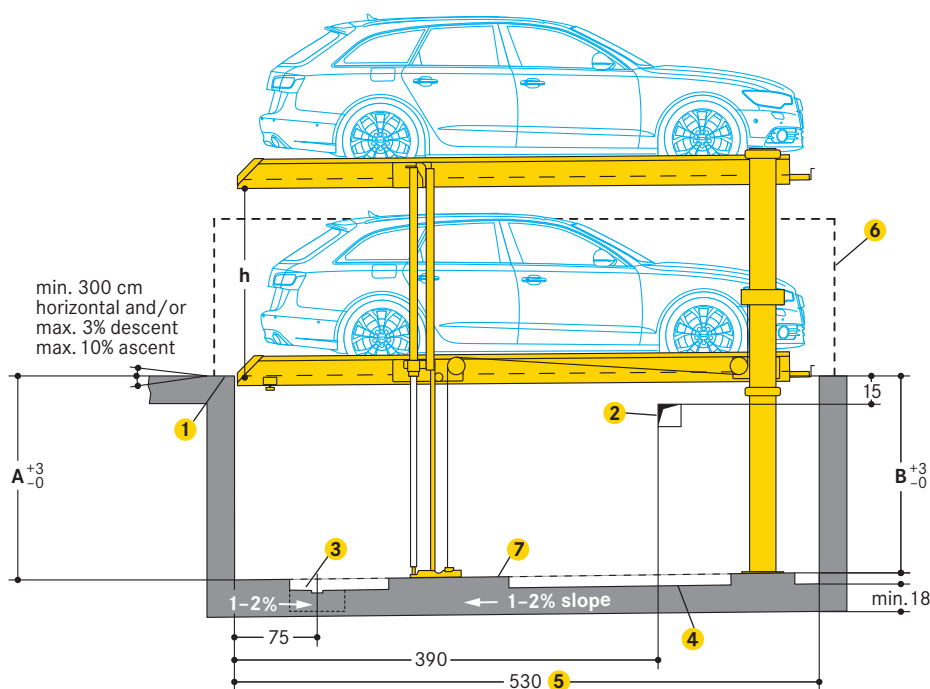

Type	Pit depth		Vehicle height LL 8	Platform distance (h)
	A	B		
450-170	170	165	L+S 150	155
450-175	175	170	L+S 155	160
450-180	180	175	L+S 160	165
450-185	185	180	L+S 165	170
450-190	190	185	L+S 170	175
450-195	195	190	L+S 175	180
450-200	200	195	L+S 180	185

Dimensions

- all dimensions specified are the minimum, finished dimensions
- tolerances must be taken into consideration
- all dimensions are given in cm

- 1 Yellow-black safety marking (performed by the customer):
 - compliant to ISO 3864, 10 cm wide, along the pit edges (see page 3 »Static calculations and construction works requirements«)
- 2 In case of intermediate walls (performed by the customer):
 - 15 x 15 cm opening for electric and hydraulic system cables and piping
 - after installation, do not close the opening
- 3 Drainage channels (performed by the customer):
 - 10 x 2 cm, with a 50 x 50 x 20 cm drainage pit
 - in case of installation of a sump pump, it is necessary to comply with the drainage pit dimensions specified by the pump manufacturer
 - above-ground garages: if there is a slope on the entrance side, a drainage channel in front of the pit edge is recommended
- 4 Channels or undercuts/concrete haunches (performed by the customer):
 - not allowed along the pit floor-to-wall joints
 - should channels or undercuts be necessary, the system width needs to be reduced or the pit needs to be wider
- 5 500 cm vehicle length = 530 cm pit length
 - for longer vehicles:
vehicle length + 30 cm safety distance = pit length (pit length max. 550 cm)
- 6 Both, rear and side barriers in accordance with DIN EN ISO 13857 are provided by the customer. Height of the barriers depending on the distance to the moving parts.
- 7 Foundation plan see page 3
- 8 L = Limousine / K = Station wagon / LL = lower level

Clearance profile (for standard vehicles)

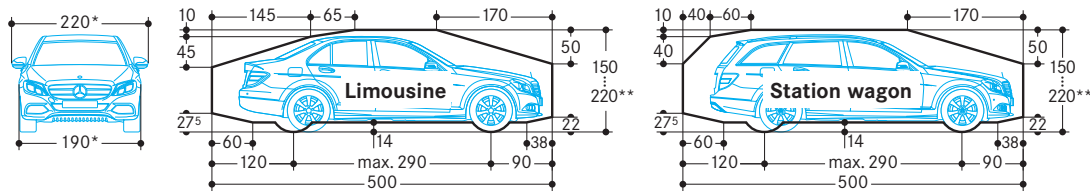

* for a 250 cm platform width
 ** The overall vehicle height including roof luggage rails an antenna mounts must not exceed the max. vehicle height dimensions specified

Width dimensions

For comfortable parking, entry and exit conditions platform widths upon 250 cm are recommended.

Reduced platform width means reduced parking comfort depending on the vehicle width, vehicle type, individual driving style, access situation of the garage.

PARKLIFT 450 (platform load upper level 1500 kg / lower level 2000 kg)

Single unit (2 cars)



space requirements B	clear platform width
260	230
270	240
280	250
290	260
300	270

Double unit (4 cars)

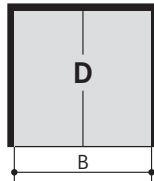

space requirements B	clear platform width
490	460
510	480
530	500
550	520
570	540

The driving aisle width must comply with local regulations

PARKLIFT 450 (platform load upper level 2000 kg / lower level 2600 kg)

Single unit (2 cars)



space requirements B	clear platform width
260	230
270	240
280	250
290	260
300	270

Double unit (4 cars)

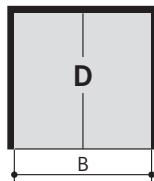

space requirements B	clear platform width
490	460
510	480
530	500
550	520
570	540

The driving aisle width must comply with local regulations

Foundation plan

Single unit

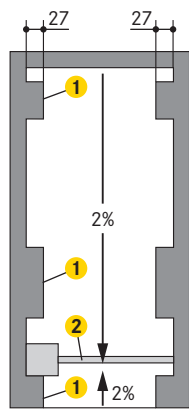

Double unit

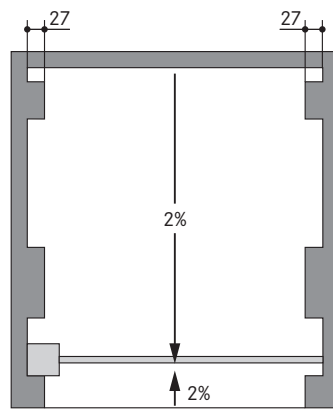

Section

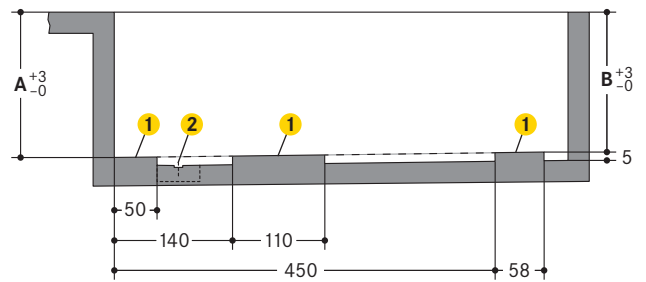

Type	A	B
Parklift 450-170	170	165
Parklift 450-175	175	170
Parklift 450-180	180	175
Parklift 450-185	185	180
Parklift 450-190	190	185
Parklift 450-195	195	190
Parklift 450-200	200	195

- 1 Block foundation 5 cm high
- 2 Recommended drainage channels:
 - 10 x 2 cm, with a 50 x 50 x 20 cm drainage pit
 - in case of installation of a sump pump, it is necessary to comply with the drainage pit dimensions specified by the pump manufacturer

Static calculations and construction works requirement

Single unit

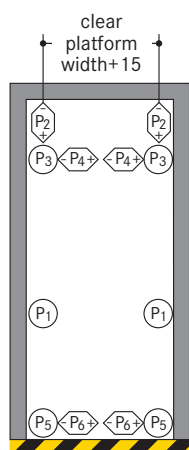

Double unit

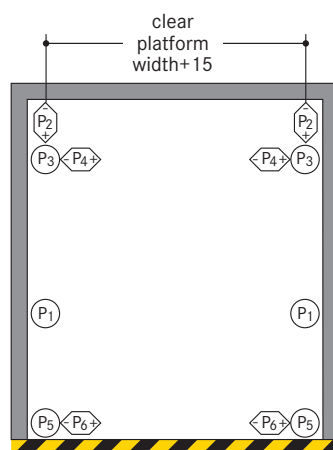

Section

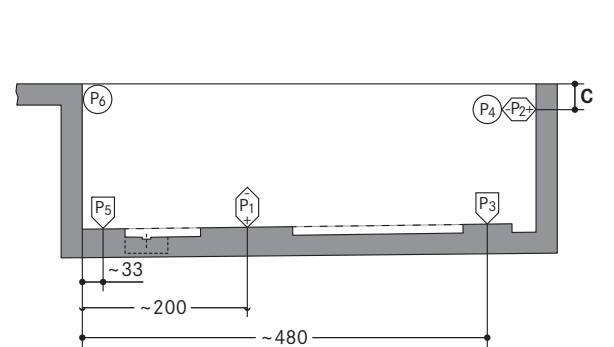

Safety marking compliant to ISO 3864

P1	+ 41 kN* - 14 kN
P2	± 3 kN
P3	+ 18 kN
P4	± 1,5 kN
P5	+ 1,5 kN
P6	± 3 kN

*specified load bearing data includes the vehicle weight

P1	+ 71 kN* - 23 kN
P2	± 3 kN
P3	+ 26 kN
P4	± 1,5 kN
P5	+ 1,5 kN
P6	± 3 kN

Type	C
Parklift 450-170	0
Parklift 450-175	5
Parklift 450-180	10
Parklift 450-185	15
Parklift 450-190	20
Parklift 450-195	25
Parklift 450-200	30

Fixing of the system frames to the floor slab:

- using base plates (approx. 140 cm²)
- using adhesive anchor bolts
- hole depth to 12-14 cm
- concrete thickness of at least 18 cm

Concrete quality grade:

- compliant to the static requirements of the construction
- min. C20/25 grade (for dowel fastening)

Walls:

- front drive-in wall, rear and side walls in concrete
- perfectly flat wall surfaces
- without protruding sections such as border edgings, pipes and tubes, etc.
- concrete thickness of at least 18 cm

Frame bearing points:

- the specified lengths are expressed as mean value
- for the exact data, specific TÜV-tested data sheets are available

Electrical specifications

Installation diagram

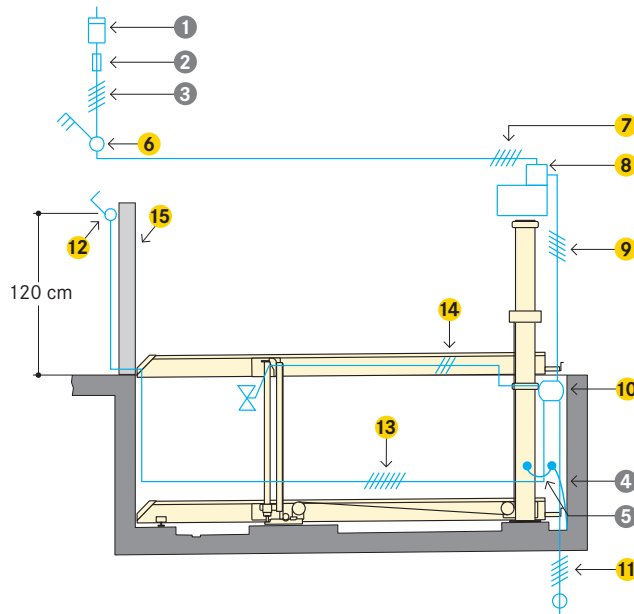

Cabling preparation to be performed by the customer:

- up to the main switch to be in place prior to starting the installation operations
- connection to the main switch during installation
- system functional check testing can be performed by WÖHR together with the electrician provided by the customer
- if requested at a later date, functional check testing can be performed by WÖHR at extra-cost

Grounding and potential equalisation (to be performed by the customer):

- compliant to DIN EN 60204
- connections required every 10 metres

To be performed by the customer

Item	Quantity	Description	Position	Recurrence
1	1 piece	power meter	in the feed cable	
2	1 piece	fuse protection or automatic circuit breaker compliant to DIN VDE 0100 part 430: - 3 x 16 A slow blow for 3,0 kW power pack (starting current 24 A) only single units - 3 x 25 A slow blow for 5,5 kW power pack (starting current 57 A)	in the feed cable	1 x per power pack
3	based on site conditions	compliant to local power supply regulations 3 phases + N + PE* 230/400 V, 50 Hz	feed cables to main switch	1 x per power pack
4	every 10 m	grounding and potential equalisation lead-out connection	along pit floor edges/rear wall	
5	1 piece	grounding and potential equalisation compliant to DIN EN 60204	from lead-out connection to system	1 x per system

* to DIN VDE 0100 sections 410 and 430 (no permanent load) 3 phases + N+ PE (three phase current)

Scope of delivery by WÖHR (unless otherwise specified)

Item	Description
6	Lockable main switch
7	5 x 2,5 ² PVC control cable leading from the main switch to the power pack
8	Hydraulic power pack with three-phase motor 3,0 kW or 5,5 kW. Ready-wired switching cabinet with motor safety contactor
9	5 x 1,5 ² PVC control cable
10	Branch connector
11	5 x 1,5 ² PVC control cable lead-out to the system alongside
12	UP/down operating unit with EMERGENCY STOP. Possibly located on the left, but always out of the platform's range of movement. Cable feed-in strictly from below leading upwards (2 keys for each parking space). Key can be removed only when in the lower end position (locked key switch)
13	7 x 1,5 ² PVC control cable
14	3 x 1,5 ² control cable for the cylinder valve lead
15	Control console with column base at extra cost

Notes and directions

Scope of application

- suitable for residential buildings, office buildings and business premises, hotels
- only for long-term users that have been instructed on how to use the system
- for frequently changing users (e.g. for office, hotel and business premises or similar):
 - only parking on top platform
 - performance of technical system adjustments is necessary
 - consultation with WÖHR is mandatory

Noise protection (outdoor installation)

Basis:

- German DIN 4109 "Noise protection in buildings"
- with devices, machines, and facilities, household appliances must provide adequate protection against transmission over air and structure-borne sound

Structure-borne sound transmission:

- since the facilities are mainly built free-standing, measures against structure-borne noise are not expected

Drainage

Drainage of large amounts of water from the courtyard area:

- circumferential drainage channel outside the pit (performed by the customer)

Water leaks into the pit:

- in the winter, up to 40 litres of snow water can possibly come with the wheel housings in just one parking process

Drainage channels:

- in the pit
- connecting to a floor drain or drainage pit (50 x 50 x 20 cm)
- cover the sump with a grate
- installation of a pump or drainage channel into the sewerage system, to be performed by the customer

Sideways slope drainage:

- only into a gutter
- not possible in the remaining pit section

Lengthways slope drainage:

- provided according to specified construction dimensions

Environmental safety:

- coating of the pit flooring is recommended
- installation of an oil and/or petrol separator unit between the drainage connection and the main sewerage system is recommended

Operating device

- position of the operating device will be defined depending on the project (control mount or house wall)
- system must always be moved to the lower end position after operation (locked key switch), thus reducing the attack surface for wind loads, avoidance of snow loads on the lower parking level

Temperature

- system operating range: -20° bis +40°C (with unloaded platforms lowering speed is reduced if less than +5° C)
- humidity: 50 % at +40° C
- in the event of changes to system conditions please consult with WÖHR

Lighting

- sufficient lighting of the driving aisle and of the parking places must be performed by the customer

Fire safety

- all fire safety requirements and all mandatory equipment (fire extinguisher and fire alarm systems, etc.) must be performed by the customer

Declaration of conformity



- The parking systems are compliant to:
- EC Machinery Directive 2006/42/EC
 - DIN EN 14010

Railings

The units need to be provided acc. EN ISO 13857 with safety railings if the gap between unit and wall exceeds 20 cm. If walkways are arranged directly to the side or behind the systems, railings have to be provided by client acc. to local requirements, height min. 200 cm - this is applicable during the construction phase too.

Hydraulic power pack

- the hydraulic power unit must be accessible via the entrance level
- sheltered from wind and weather (not in residential buildings)
- space requirements:
 - 100 x 140 x 35 cm (H x W x D)
- sound insulation hood for protection against rain and airborne sound transmission at extra cost
- two systems per power unit at the most
- please consider lengthier lowering time when outside temperatures are low
- system standstill possible when temperatures are below zero
- power unit heating recommended (at extra cost)

Maintenance

- WÖHR and all the WÖHR partners abroad provide an installation and customer service network
- regular, annual maintenance is provided subject to the stipulation of a maintenance agreement

Prevention of corrosion damage

- all operations listed in the WÖHR Cleaning and Maintenance Instructions are to be performed regularly (independently of maintenance operations)
- zinc-plated parts, components and platforms are to be kept clean of dirt, road-salt and any other debris (due to corrosion hazards)
- always keep the garage well ventilated and deaerated



Surface protection

- please consider the information on surface protection!



Tender specification

- please consider the specifications!



Parking Place-Profile

- please consider the product information Parking Place-Profile!



Electromobility

- please consider the product information E-charging!
- depending on the position of the charging point on the electric vehicle, collision points with protruding plugs and charging cables can occur



Construction formalities

- the documentation necessary for construction permit applications is provided by WÖHR on demand

Construction alterations and/or modifications

- the right to construction or model modifications and/or variations is hereby reserved
- the right to any subsequent part modification and/or variation and amendments in procedures and standards due to technical and engineering progresses or due to environmental regulation changes is also hereby reserved