

Oct. 2020
RENEWAL

Motorized Curtain Track

Progress 25/50/80

Made in JAPAN

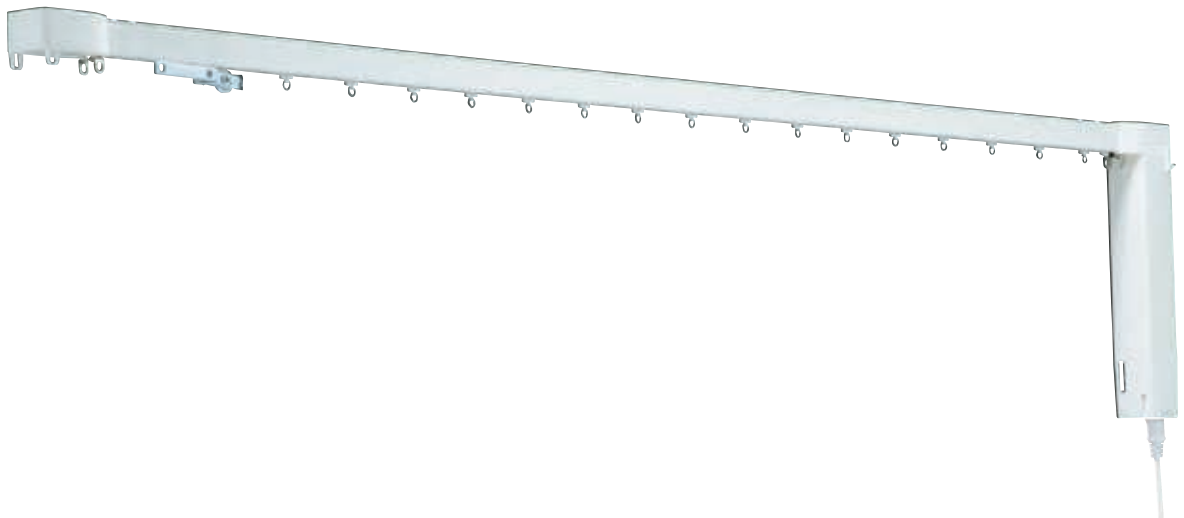

- Motorized curtain track with ultra-quiet operation. (Less than 35 dB)
- Smooth manual-override (by hand-draw operation).
- Automatically identifies and set Open and Stop operation limits.
- EMC Design and Certification.
- Wave Style is available.
- Enables opening/closing of curtains without using any switch operations. (Touch Motion)
- Intermediate limits can be set for both the opening and closing directions.

Progress 25/50/80

Progress 25/50/80's Unique Features

Feature 1: Quiet operation with a new motor and new rollers

The new motor and rollers provide ultra-quiet operation.

Feature 2: Smooth hand-draw operation as well as motor operation

A built-in electromagnetic clutch allows the drapery to be drawn by hand.

Feature 3: Can be curved into a variety of shapes

L-shaped, U-shaped, S-shaped and gradual curves.

Feature 4: Highly durable belt drive transmission system

The belt drive transmission system is highly durable.

Feature 5: "Slow start" and "Slow stop" functions

These functions enable the smooth start and stop of drapery operation.

Feature 6: Adjustable curtain open/close speed

The speed of operation is adjustable in 10 stages (from 4.5 to 11.0 seconds per meter).

This allows you to select the speed that best matches each window.

Feature 7: Touch motion function

The touch motion function can perform opening/closing of curtains without using any switch.

When curtain is drawn, it will begin to move in the direction itself, and will stop at the place on limit setup.

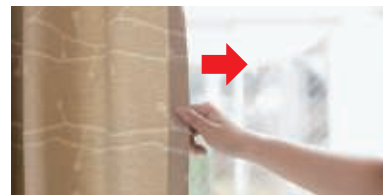

Feature 8: Intermediate Limit function

The Intermediate Limit function stops the curtain at the desired position.

Feature 9: "EMC* Design and Certification

Electromagnetic compatibility (EMC) means that a device is compatible with (i.e., no interference is caused by) its electromagnetic (EM) environment and it does not emit levels of EM energy that cause electromagnetic interference (EMI) in other devices in the vicinity.

Feature 10: Acceleration Mode is available

The industry's first "acceleration feature" is installed as a function of the Motorized Curtain Track. Press and hold the button for about 3 seconds to maximize speed.

Feature 11: Rotation Direction Selecting

This function enables switching of motor rotation direction without reassembling the Rail Set. Use this if the Rail Set has been accidentally assembled in the reverse orientation.

Feature 12: Reduce of standby power

Standby power 0.5 W due to improved motor control board.

Product Overall View and Names of Parts

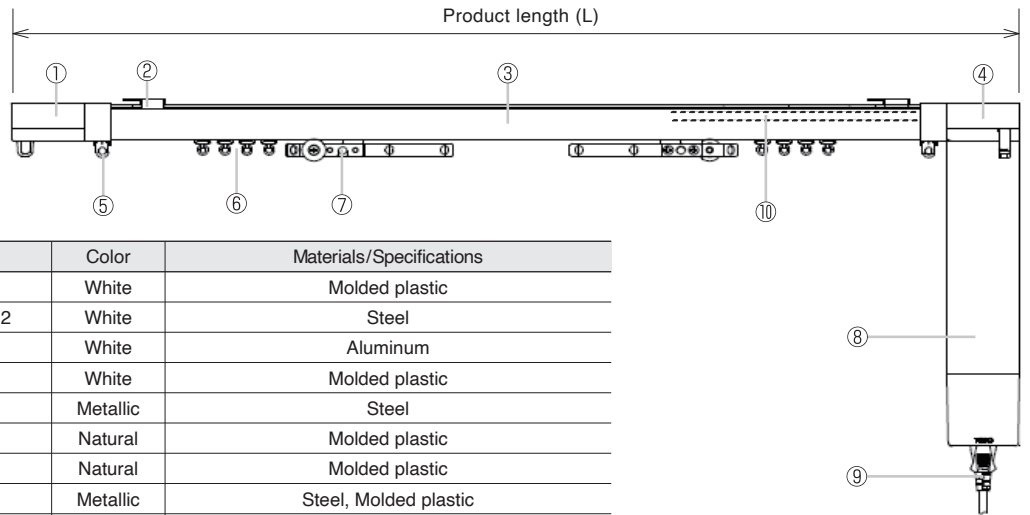

No.	Product Name	Color	Materials/Specifications
①	End side Pulley	White	Molded plastic
②	Ceiling Single Bracket M2	White	Steel
③	Track	White	Aluminum
④	Motor side Pulley	White	Molded plastic
⑤	Stop	Metallic	Steel
⑥	Noiseless Roller	Natural	Molded plastic
	New Delac Roller	Natural	Molded plastic
⑦	Pilot Roller Set	Metallic	Steel, Molded plastic
⑧	Motor	White	Aluminum, molded plastic (case)
⑨	Power Cord	White	Wire with plug (1 m/39")
⑩	Drive Belt	Green	3-layer structure of steel wires, plastic and fiber

Track Cross Section

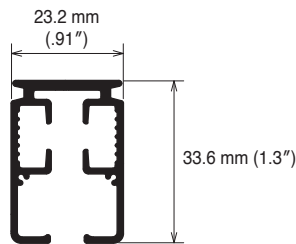

Installation Dimensions

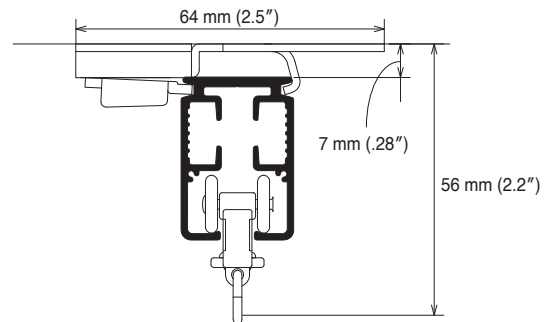





Motor Specifications

	Progress 25	Progress 50/80
Rated power voltage	AC 100 to 240 V	
Rated power frequency	50/60 Hz	
Power consumption	During stand by: 0.5 W or lower Max. load operation: 86 W	
Operating voltage	DC 24 V	
Operating current	3 mA	
Power rating	0.86 A (AC 100 V), 0.48 A (AC 240 V)	
Operating speed	5 to 11.5 sec./m (variable in 10 stages)	4.5 to 11.0 sec./m (variable in 10 stages)
Rated current	0.59 N.m	0.98 N.m
Ambient temperature	0 to 50°C (non-condensing)	
Time rating	8 min. (continuous operation)	
Noise level	Less than 35 dB (in 9.5 sec./m)	

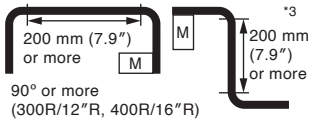
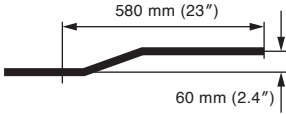

Applicable Range

Specifications		Progress 25		Progress 50		Progress 80 ^{*5}	
		Curtain Weight ^{*4}	Product Length	Curtain Weight ^{*4}	Product Length	Curtain Weight ^{*4}	Product Length
Straight 	One-way Draw	25 kg (55 lb)	1,000 mm (39") to 10,000 mm (394")	50 kg (110 lb)	1,000 mm (39") to 15,000 mm (591")	80 kg (176 lb)	1,000 mm (39") to 15,000 mm (591")
	Two-way Draw	25 kg (55 lb) [One-way Draw: 12 kg (26 lb)]		50 kg (110 lb) [One-way Draw: 25 kg (55 lb)]		80 kg (176 lb) [One-way Draw: 40 kg (88 lb)]	
Single Curve ^{*1}  90° or more (300R/12"R, 400R/16"R)	One-way Draw	15 kg (33 lb)	1,200 mm (47") to 10,000 mm (394")	35 kg (77 lb)	1,200 mm (47") to 10,000 mm (394")	50 kg (110 lb)	1,200 mm (47") to 10,000 mm (394")
	Two-way Draw	15 kg (33 lb) [One-way Draw: 7 kg (15 lb)]		35 kg (77 lb) [One-way Draw: 17 kg (37 lb)]		50 kg (110 lb) [One-way Draw: 25 kg (55 lb)]	
Two Curves ^{*1} (U-shaped or S-shaped)  90° or more (300R/12"R, 400R/16"R)	One-way Draw	15 kg (33 lb)	1,500 mm (59") to 6,000 mm (236")	25 kg (55 lb)	1,500 mm (59") to 10,000 mm (394")	35 kg (77 lb)	1,500 mm (59") to 10,000 mm (394")
	Two-way Draw	15 kg (33 lb) [One-way Draw: 7 kg (15 lb)]		25 kg (55 lb) [One-way Draw: 12 kg (26 lb)]		35 kg (77 lb) [One-way Draw: 17 kg (37 lb)]	
Overlap Track 	One-way Draw	15 kg (33 lb)	1,000 mm (39") to 10,000 mm (394")	35 kg (77 lb)	1,000 mm (39") to 10,000 mm (394")	50 kg (110 lb)	1,000 mm (39") to 10,000 mm (394")
Overall Curve Half ^{*2}  1,000R (39"R) or more	One-way Draw	15 kg (33 lb)	1,000 mm (39") to 6,000 mm (236")	25 kg (55 lb)	1,000 mm (39") to 7,000 mm (276")	35 kg (77 lb)	1,000 mm (39") to 10,000 mm (394")
	Two-way Draw	15 kg (33 lb) [One-way Draw: 7 kg (15 lb)]		25 kg (55 lb) [One-way Draw: 12 kg (26 lb)]		35 kg (77 lb) [One-way Draw: 17 kg (37 lb)]	

^{*1} With regular curve radius of 300R (11.8"R) or 400R (16"R), curve bending is available in the range of 90° to 179°.

^{*2} Overall curve half is available with a curve radius of 1,000R (39"R) or more. The number of splice is one piece only, and two tracks need to be spliced in the center.

^{*3} A splice between two curves requires at least 400 mm (16") of a straight portion, and a non-splice between two curves requires at least 200 mm (7.9") of a straight portion.

^{*4} An allowable curtain load per roller is 1.5 kg (3.3 lb) or less.

^{*5} Progress 50/80 motor is the same one. Please use New Delac Roller over 50 kg (110 lb).

Product Size (Pilot Roller with Arm)

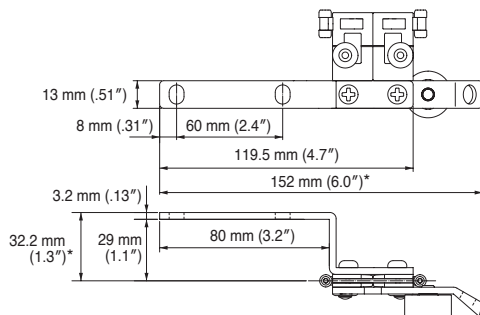

* With Arm

Installation Dimensions and Diagram

Two-way draw: ceiling single attachment

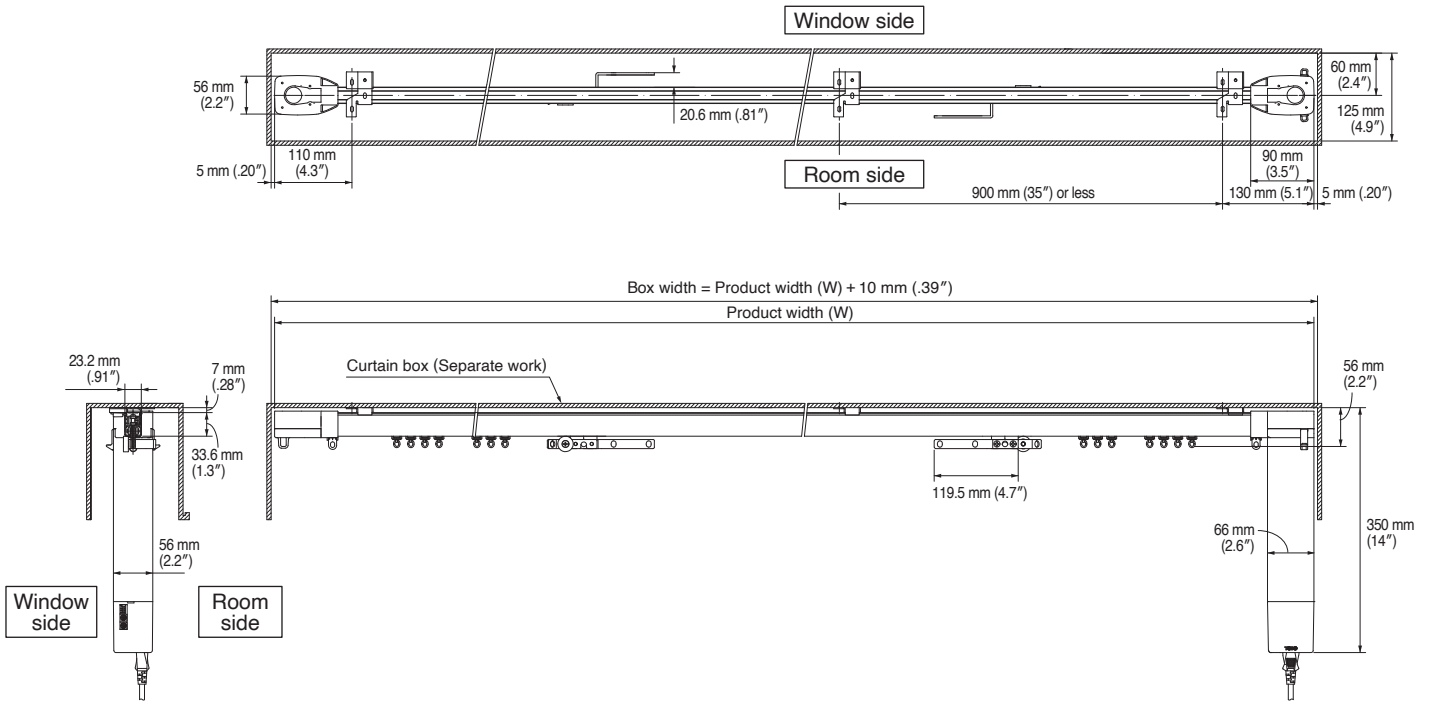

Two-way draw: ceiling double attachment

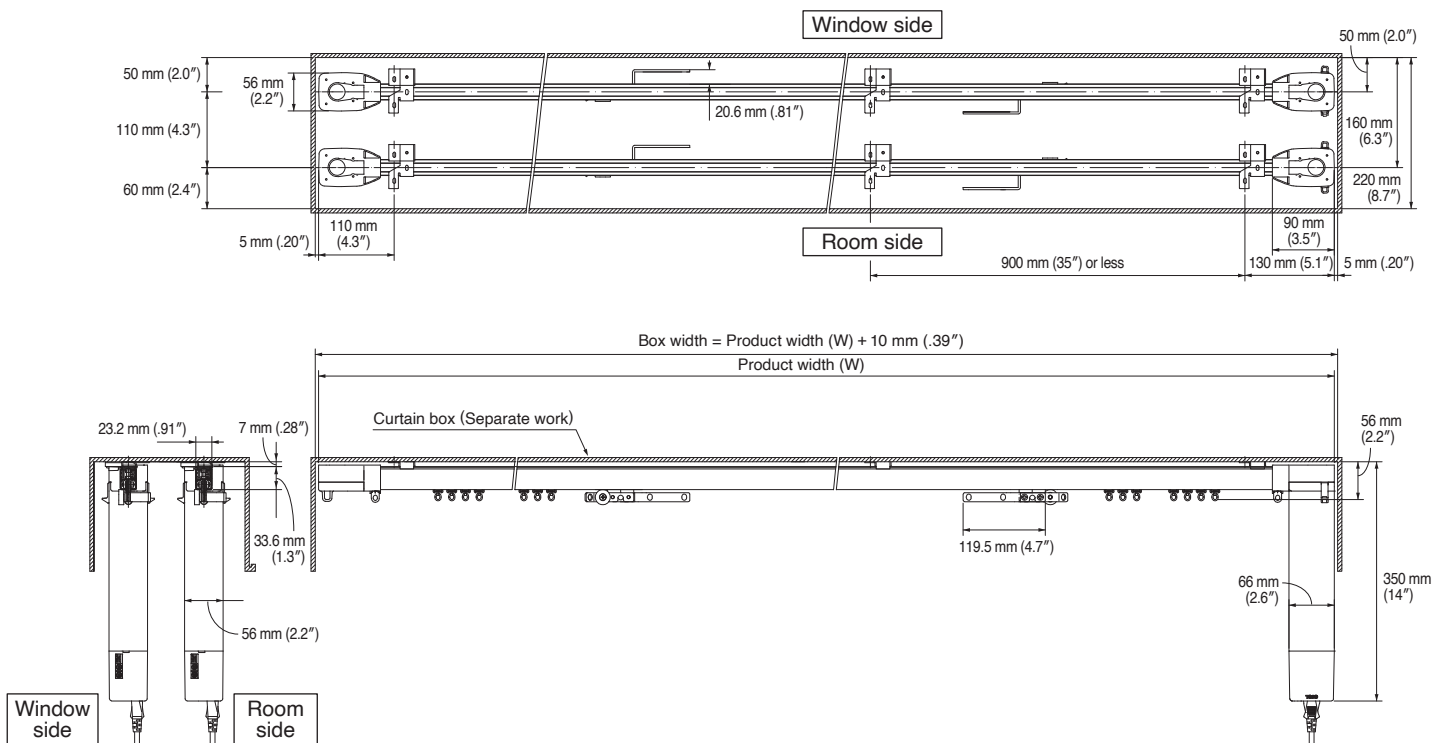

Two-way draw: ceiling single attachment
(Overlap with two tracks)

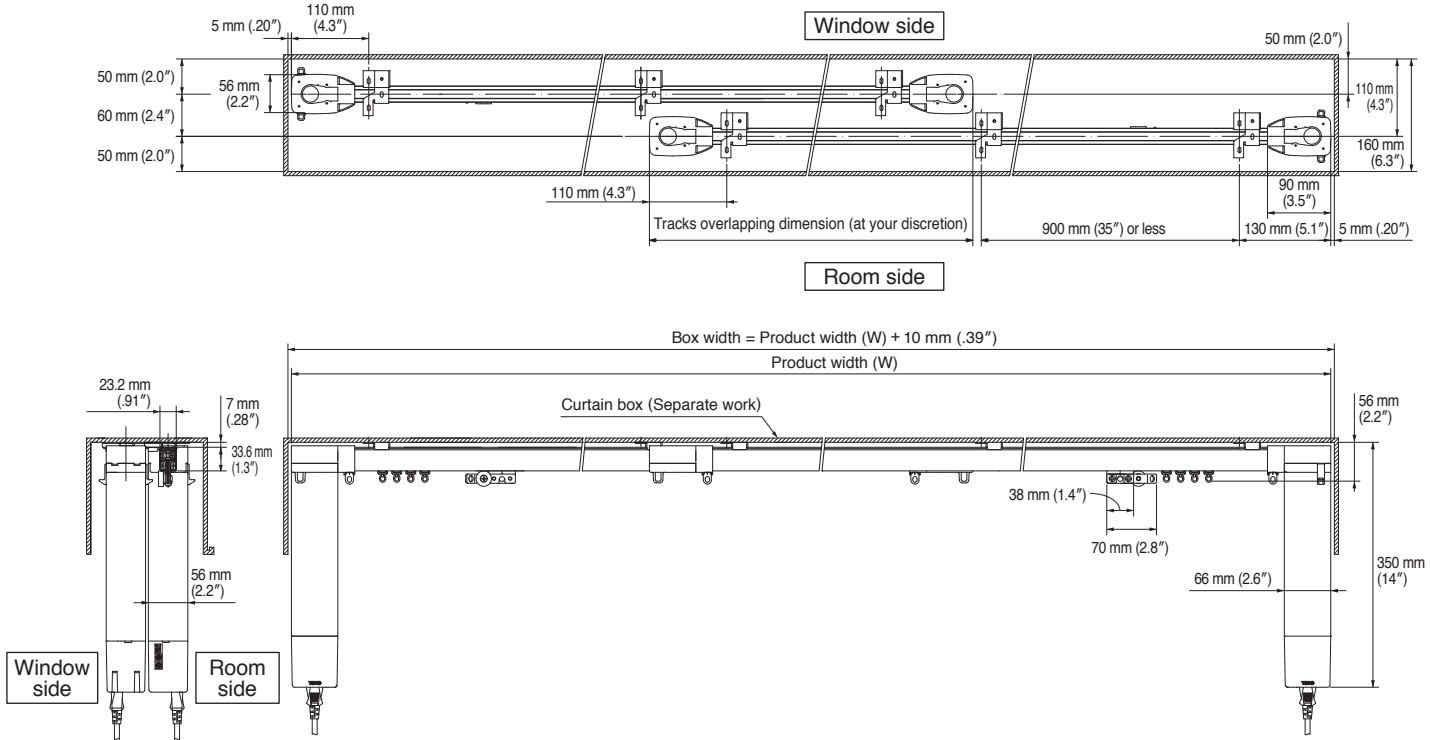

Two-way draw: ceiling double attachment
(Room side: Overlap with two tracks, Window side: Master Roller)

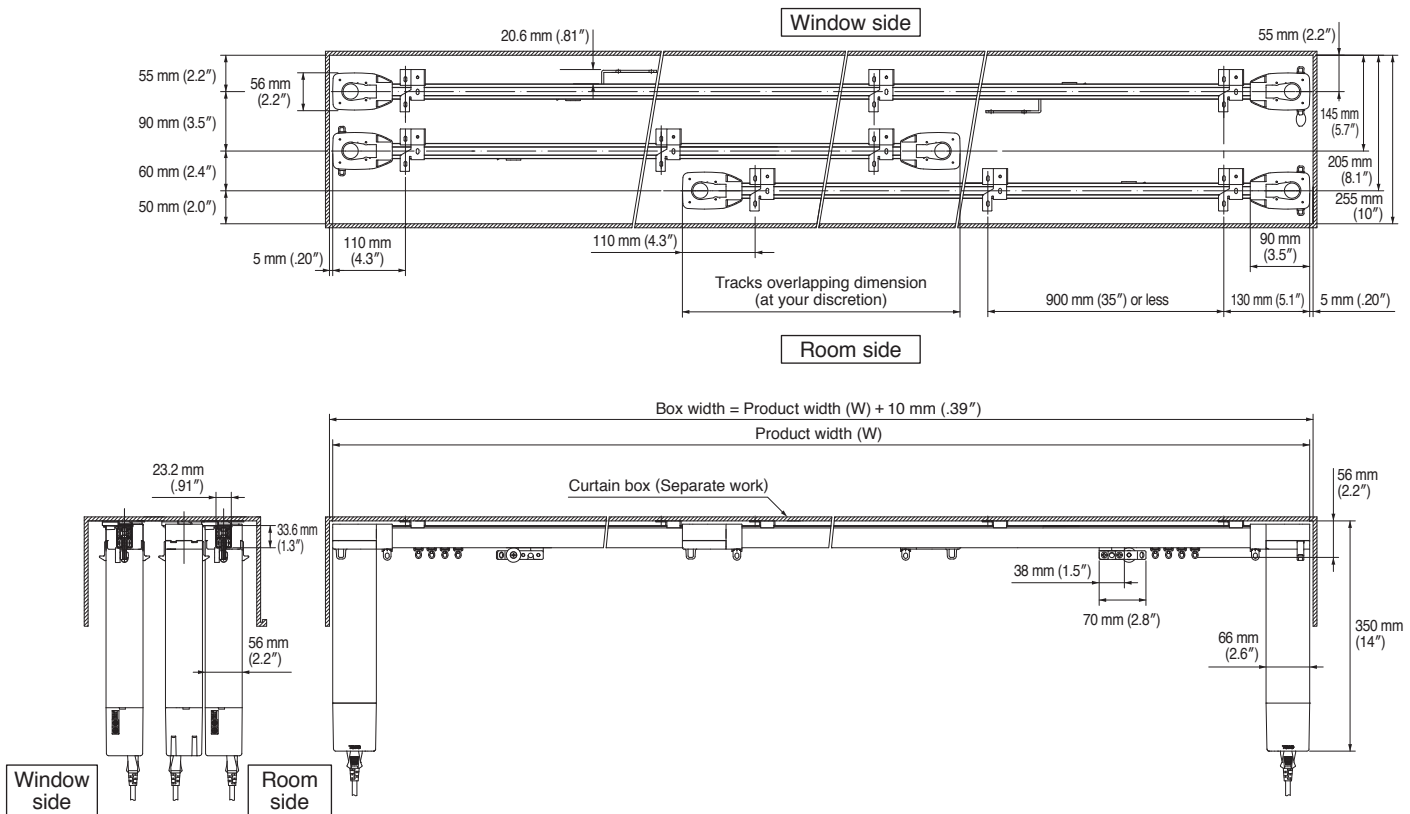

Two-way draw: ceiling single attachment
(Overlap track)

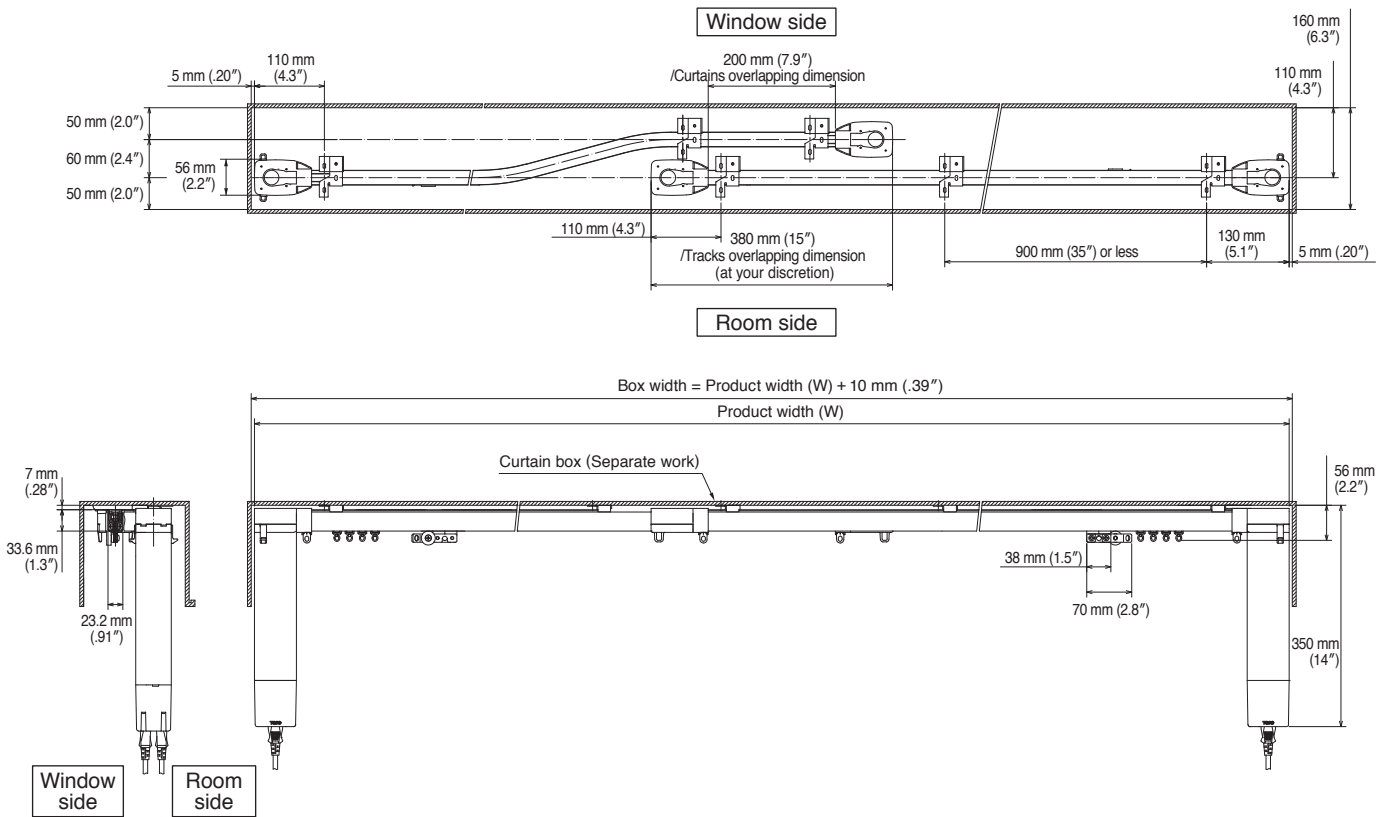

Two-way draw: ceiling double attachment
(Room side: Overlap track, Window side: Master Roller)

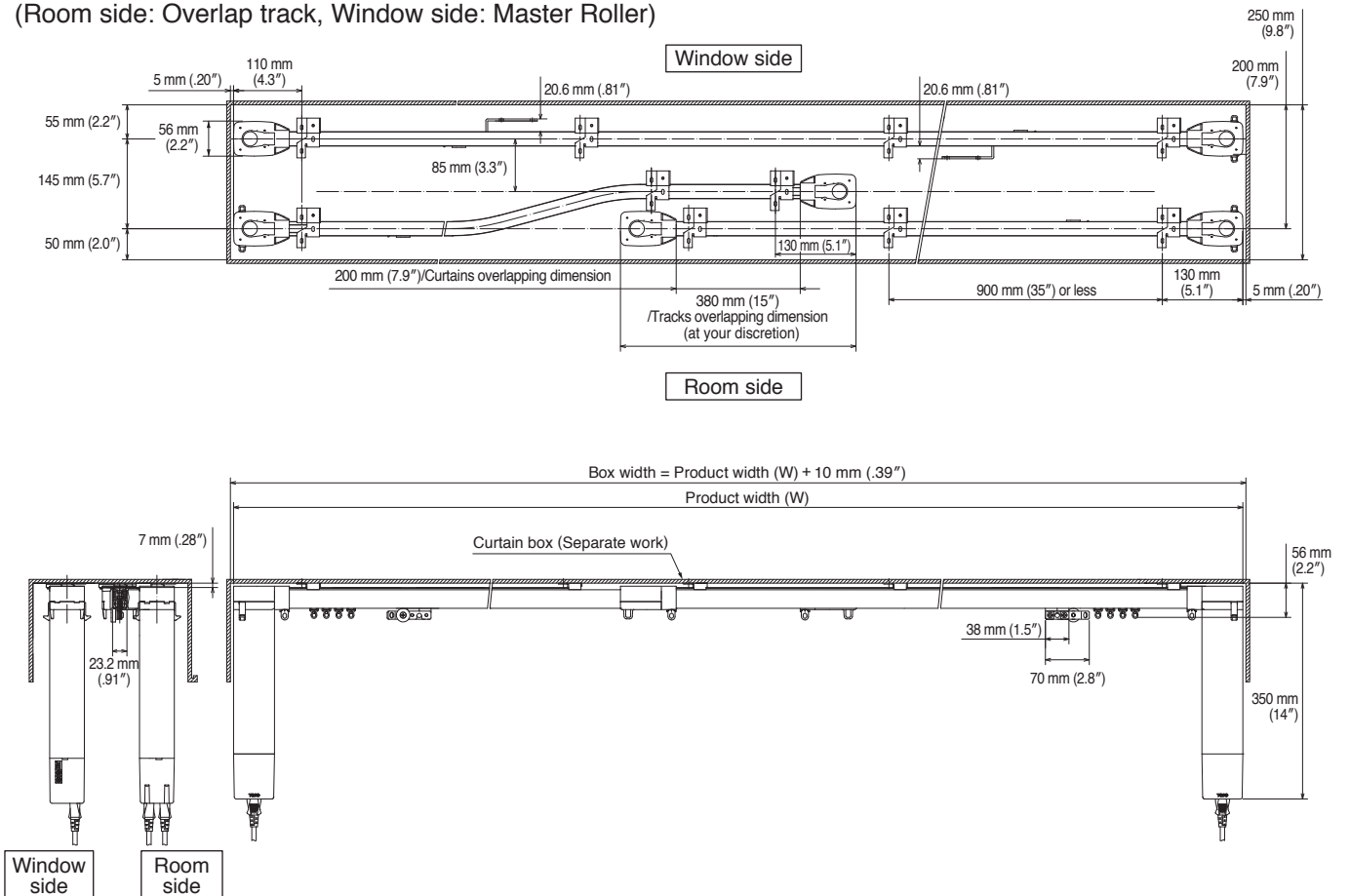

Single curve: ceiling single attachment

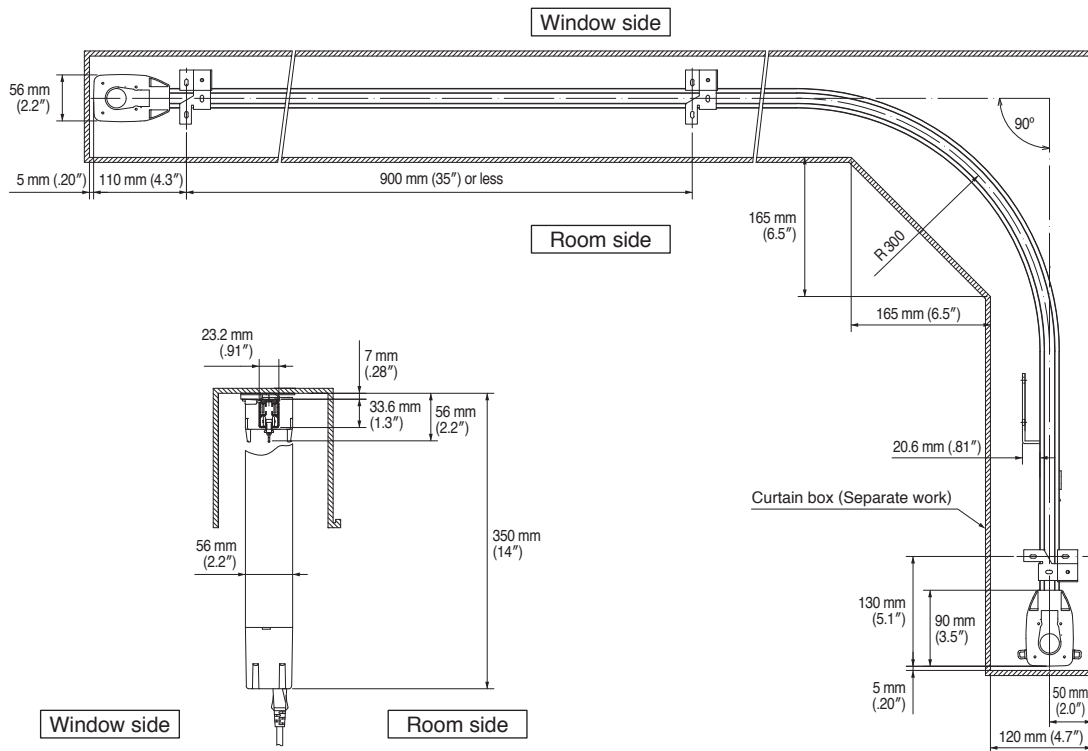

Single curve: ceiling double attachment

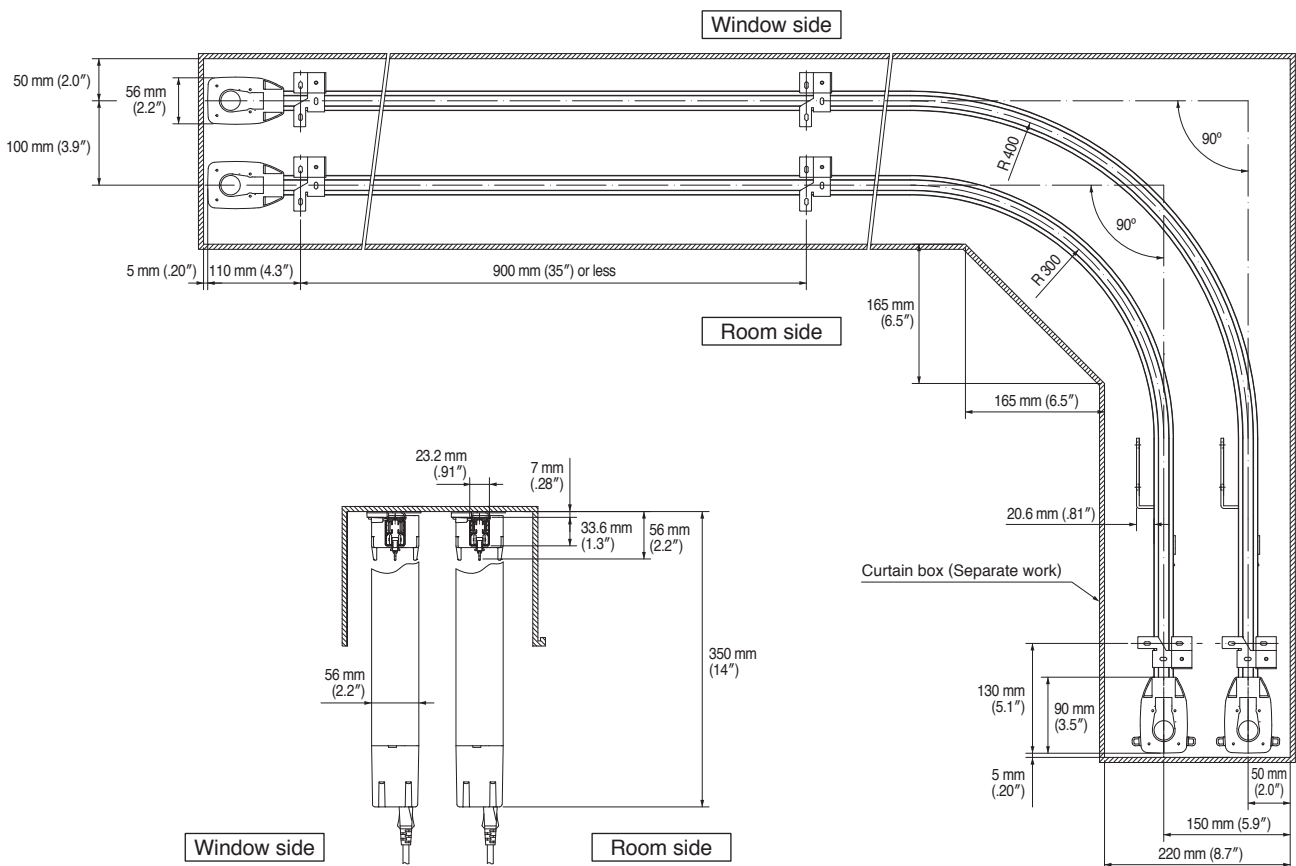

Two curves: ceiling single attachment

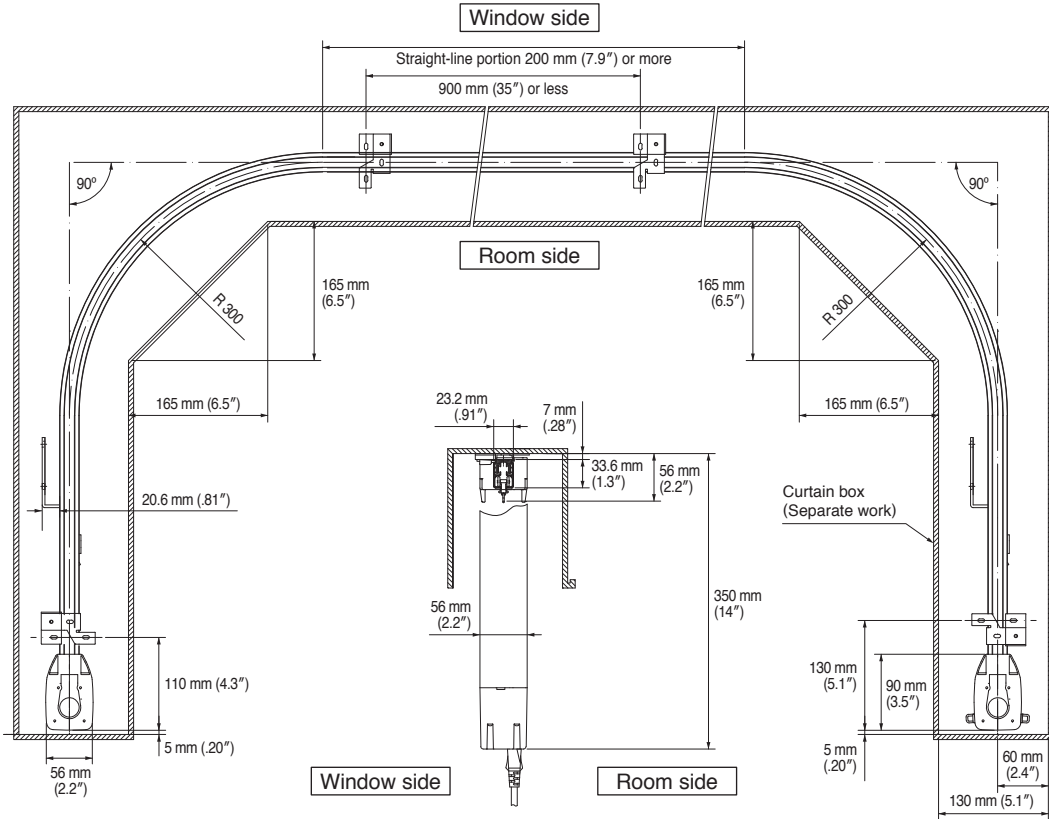

Two curves: ceiling single attachment

(Room side: Overlap with two tracks, Window side: Master roller)

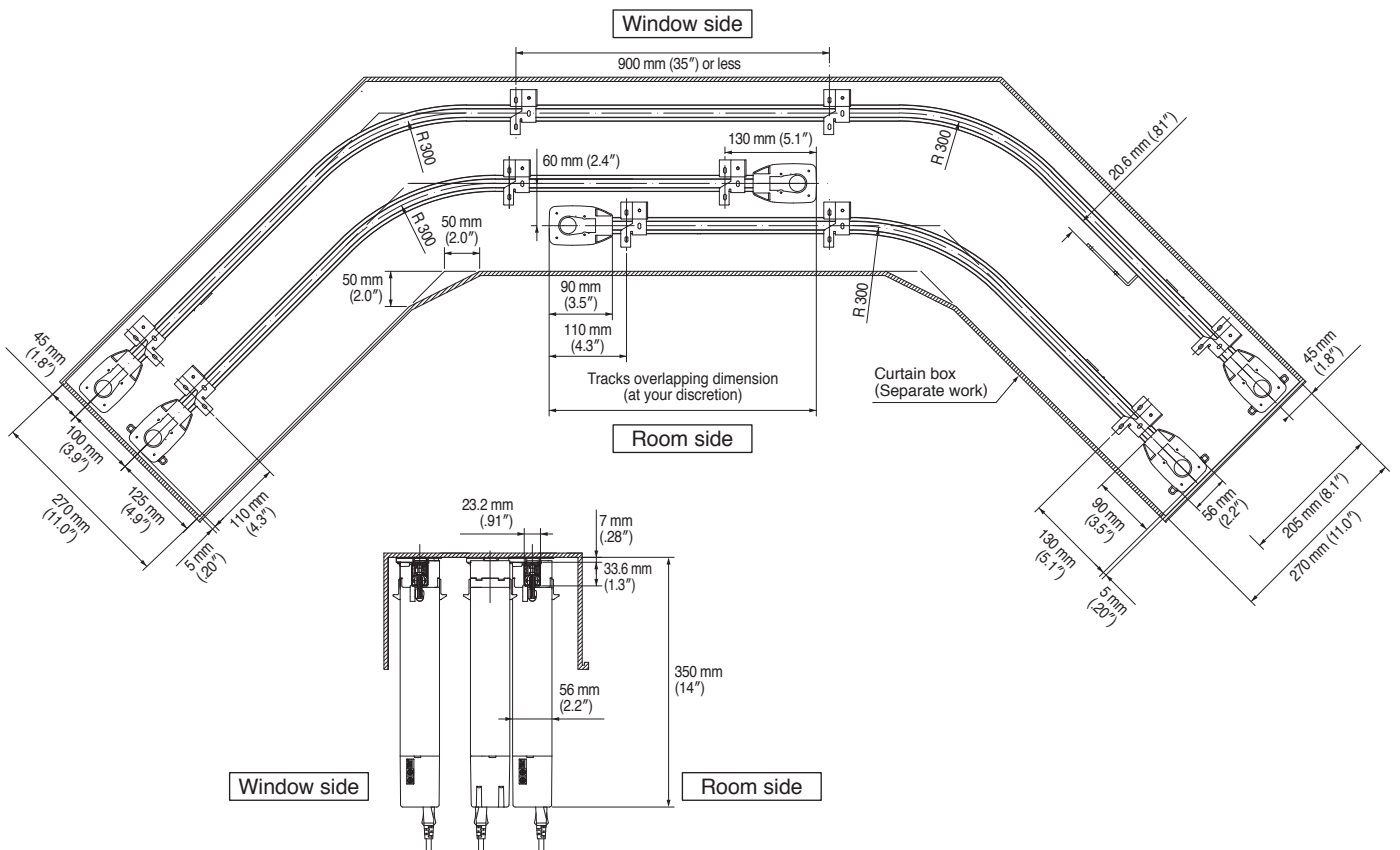

Two curves (S-shaped): ceiling single attachment

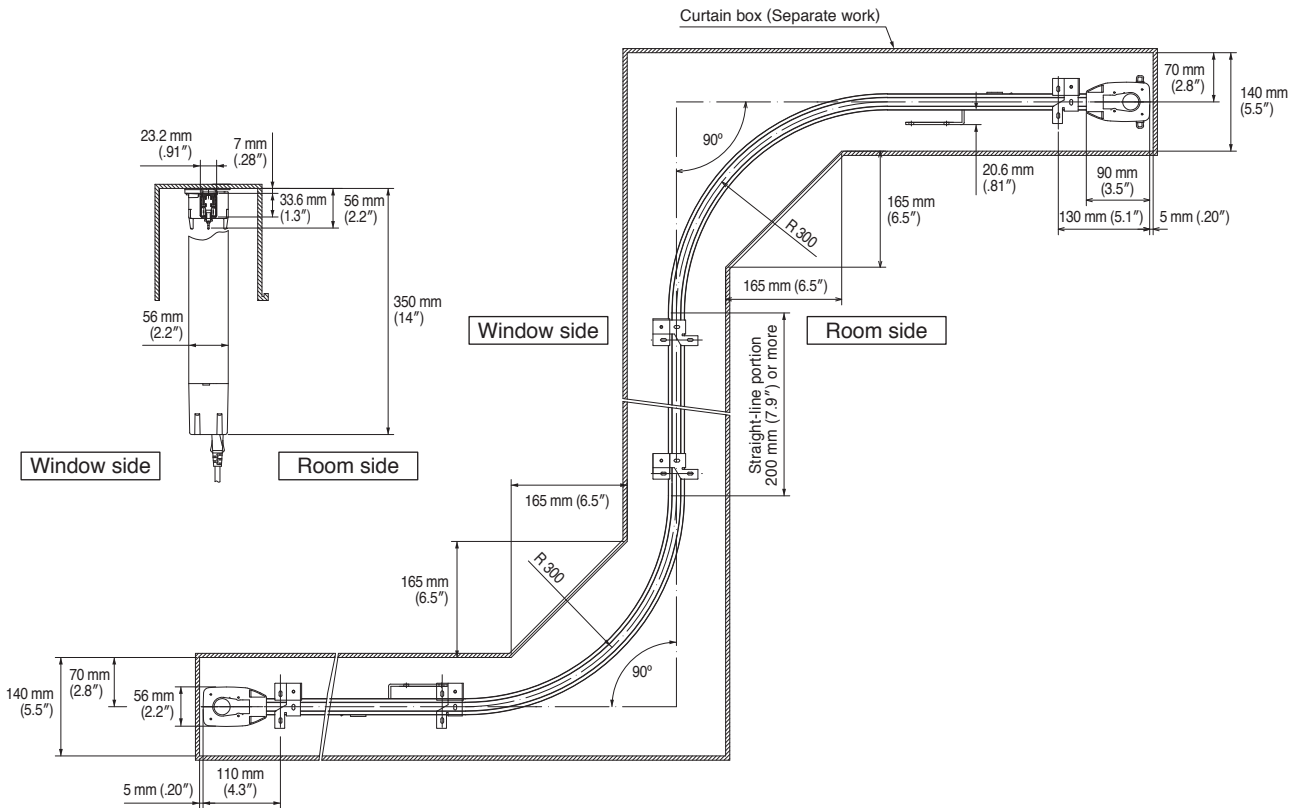

Overall curve: ceiling single attachment

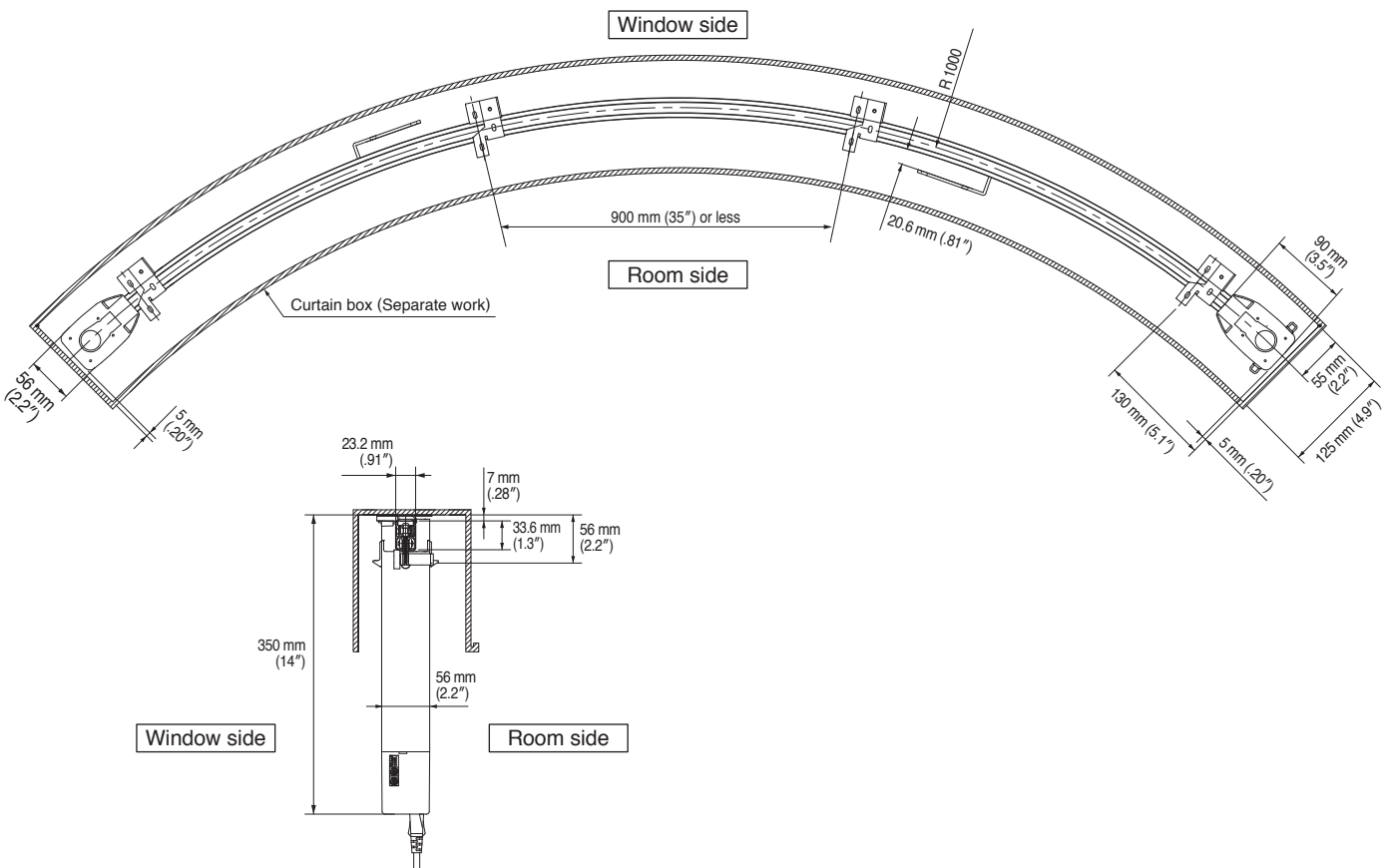

Overall curve half: ceiling double attachment
 (Room side: Overlap with two tracks, Window side: Master roller)

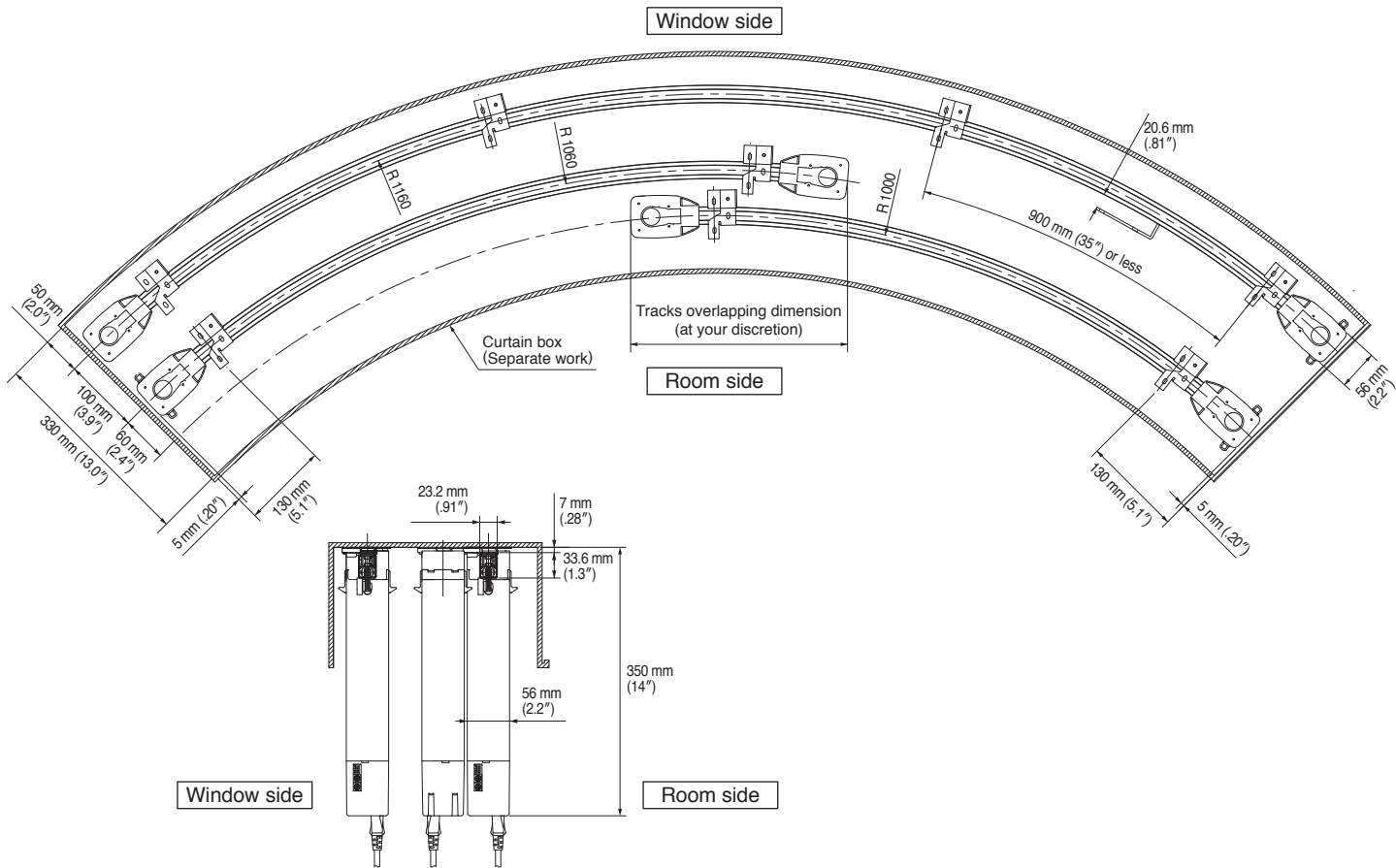

Basic Wiring and Connecting Diagram

Single Operation

Basic Wiring Diagram

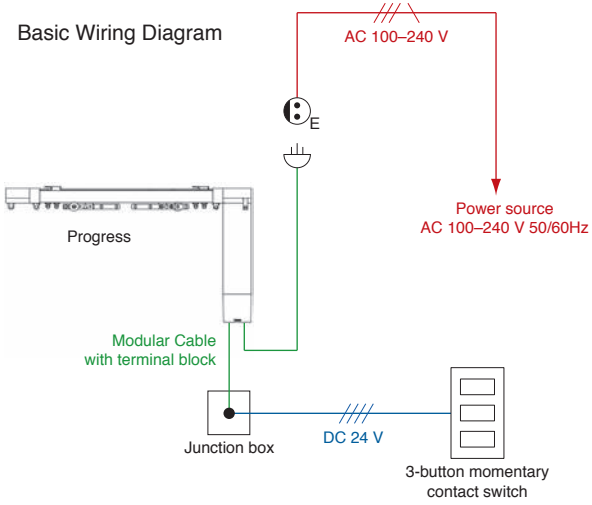

Basic Connecting Diagram

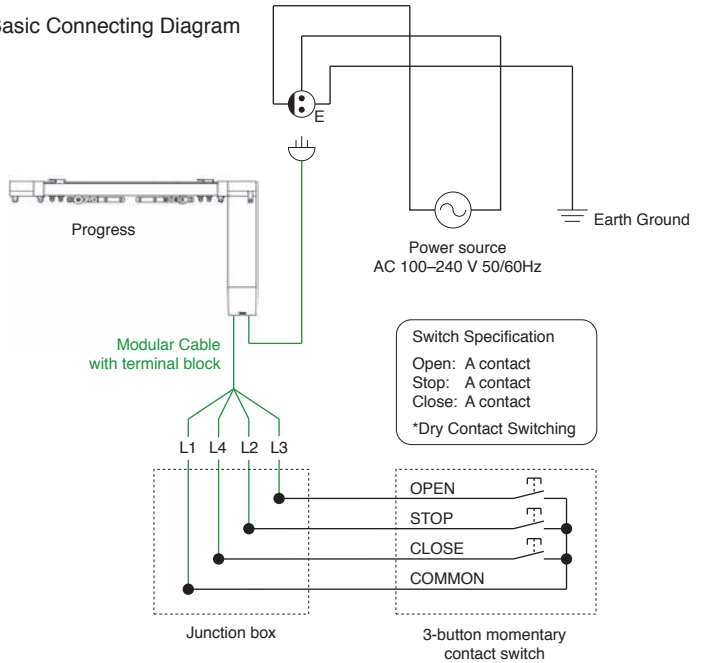

Operation from Two Locations

Basic Wiring Diagram

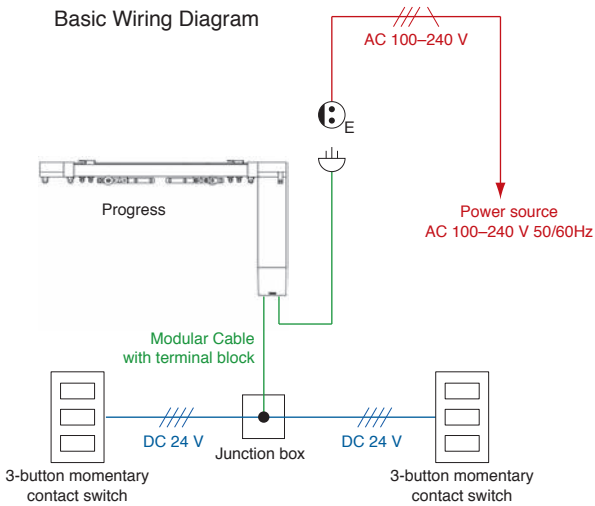

Basic Connecting Diagram

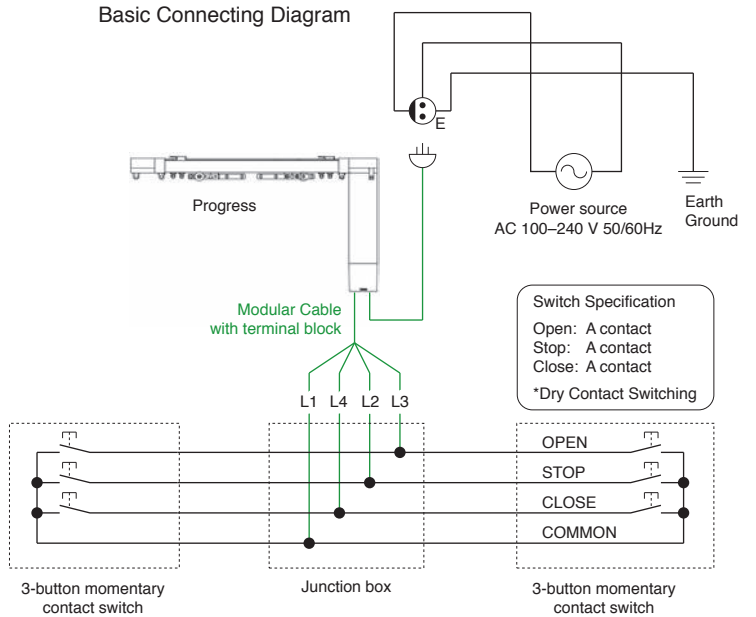

Simultaneous Operation

Basic Wiring Diagram

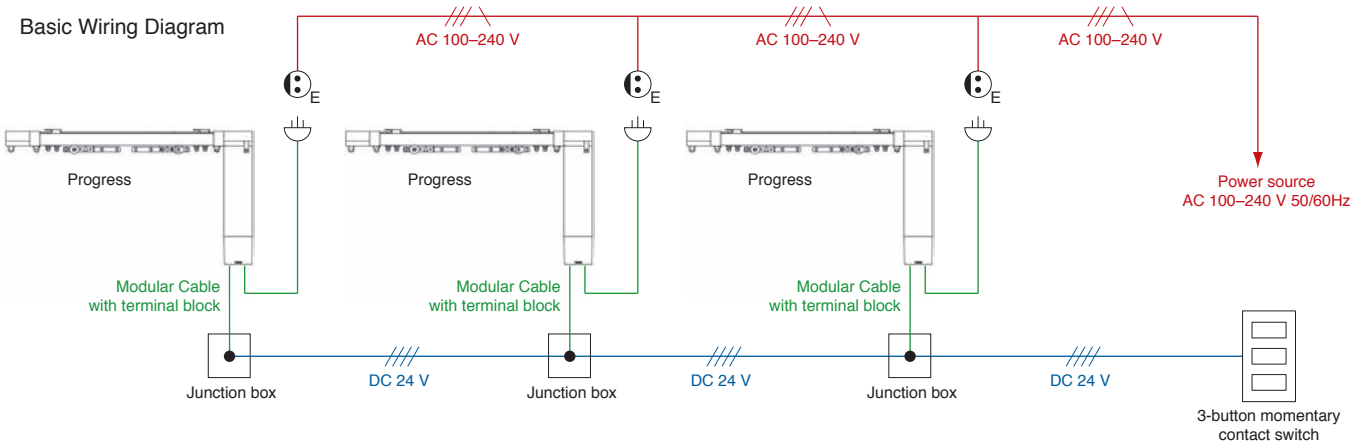

Basic Connecting Diagram

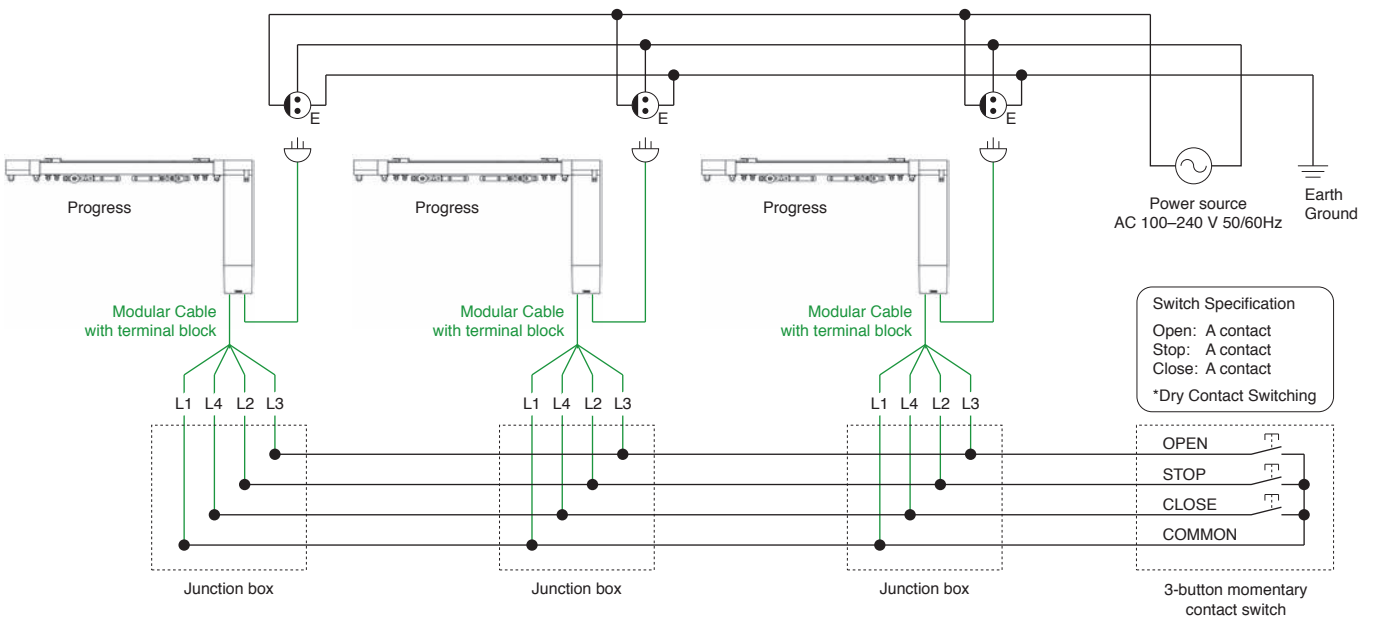

Explanatory notes: — Power supply, — Low voltage control line, — Main body attachment or TOSO standard

Simultaneous Operation for Select

Basic Wiring Diagram

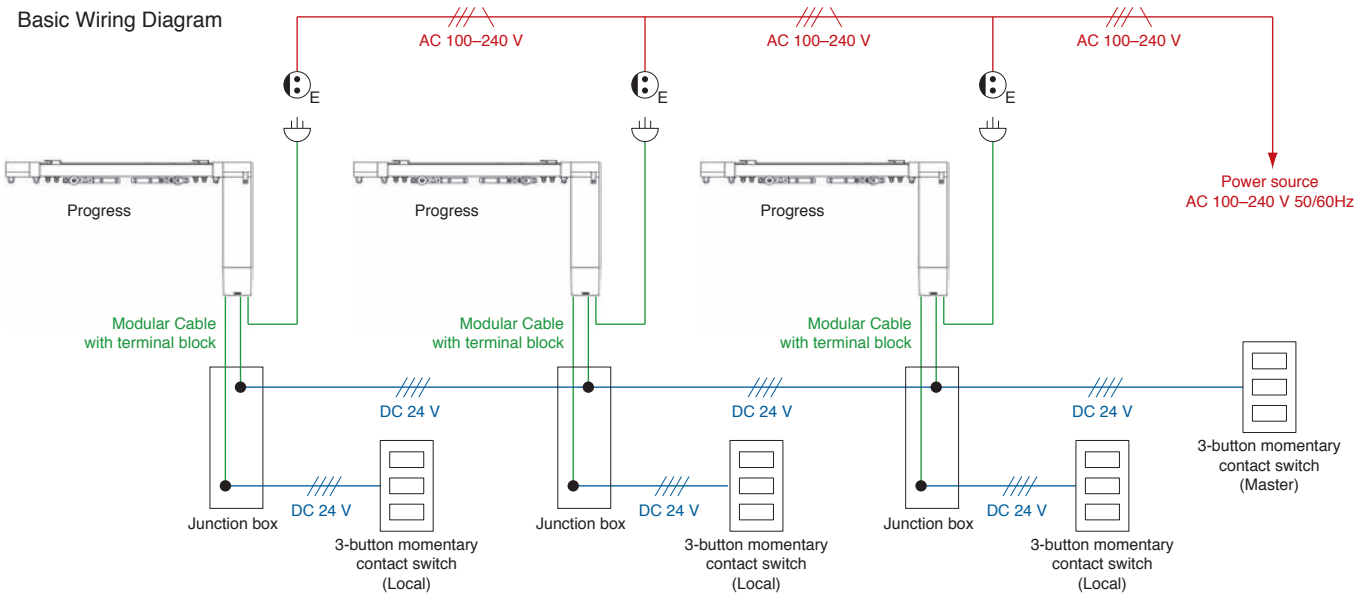

Basic Connecting Diagram

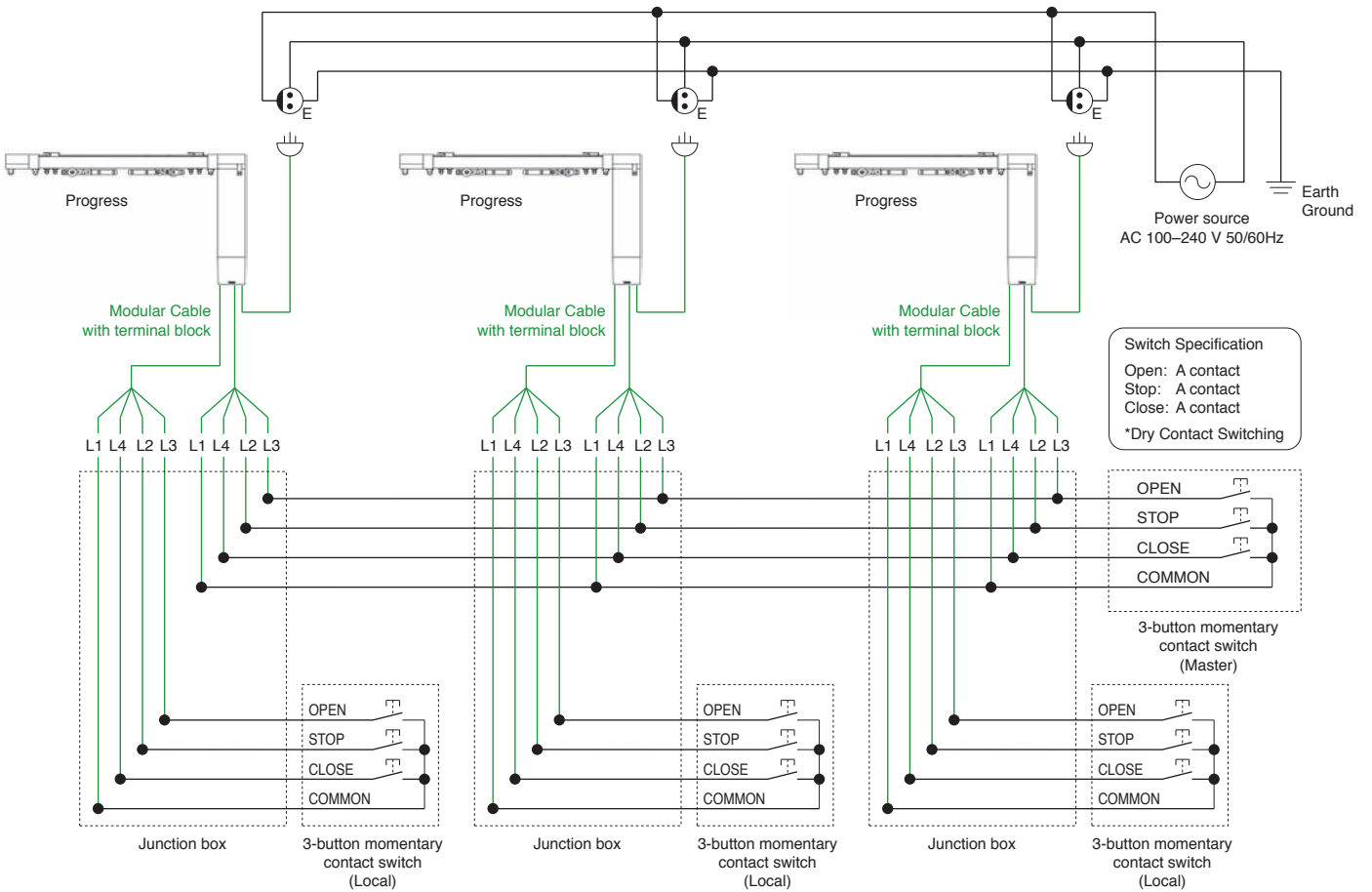

Infra-red Operations

Basic Wiring Diagram

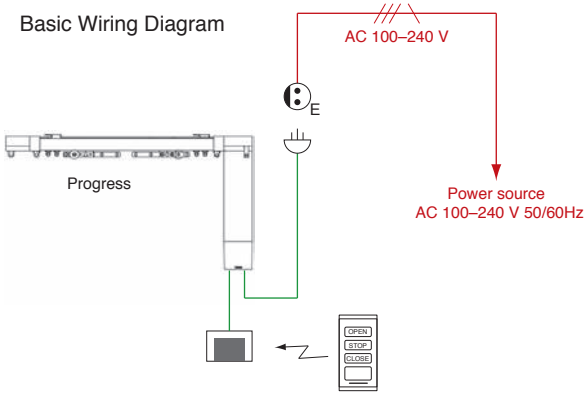

Basic Connecting Diagram

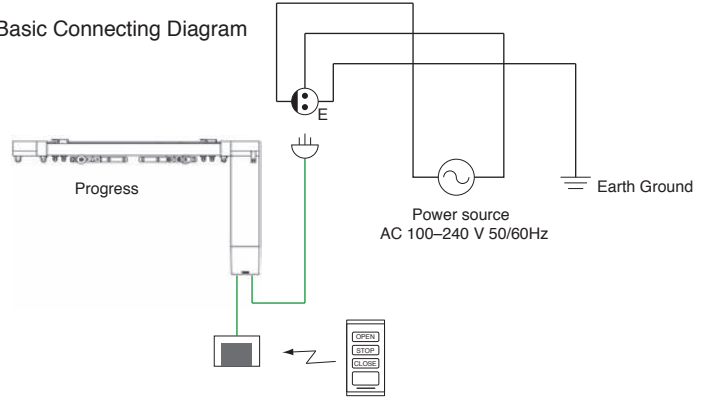

FM Remote-Control Receiver 2.4G with IR Terminal

Basic Wiring Diagram

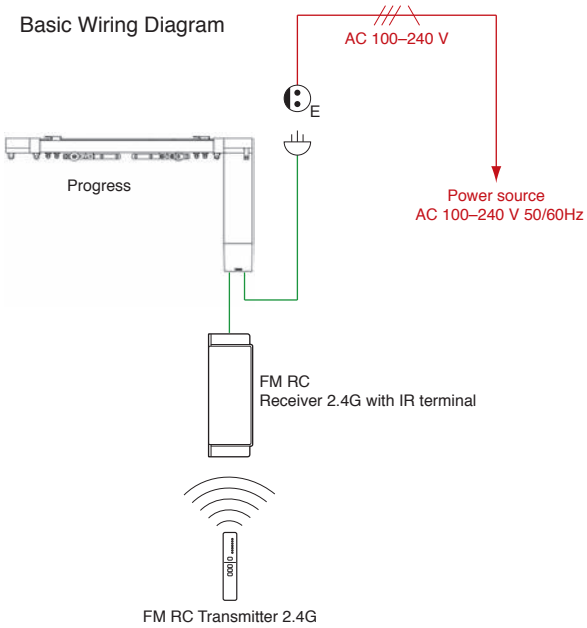

Basic Connecting Diagram

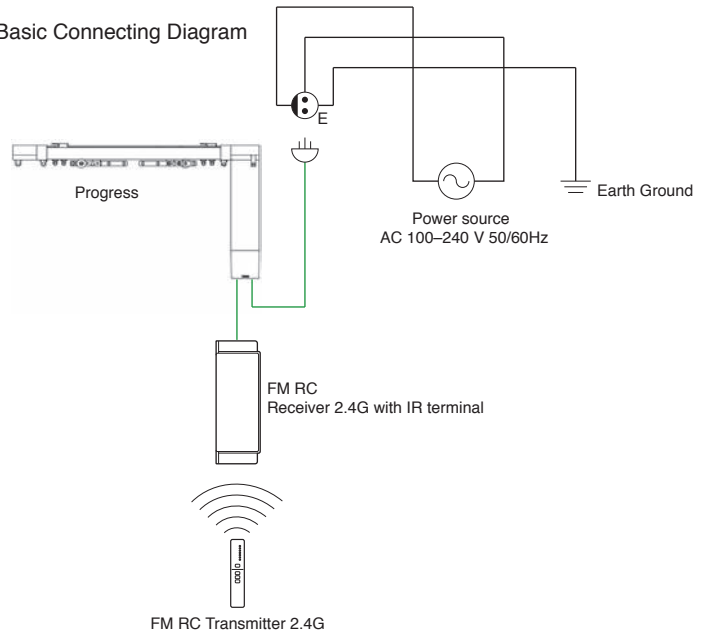



Explanatory notes: — Power supply, — Low voltage control line, — Main body attachment or TOSO standard

Progress 25/50/80 Track

White Track

Size	Product Code
5.00 m (197")	04990014

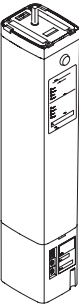
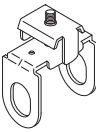
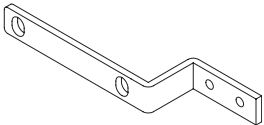
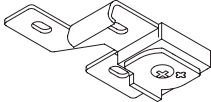
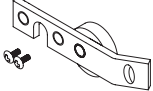
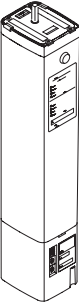
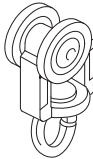
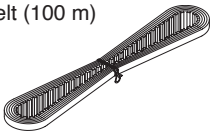
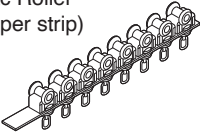
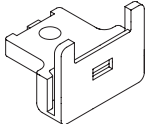
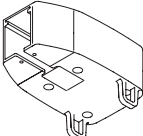
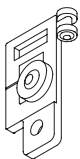
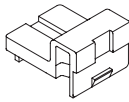
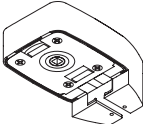
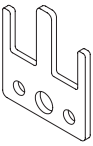
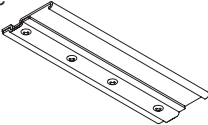
Progress 25/50/80 Parts

Product Name	Product Code	Product Name	Product Code	Product Name	Product Code
Progress 50 Motor Set * 	30015972	Progress 50 Stop 	04990022	Master Roller Arm 	04990012
		Ceiling Single Bracket M2 	30007811	Pilot Roller Plate with Wheel 	04990013
Progress 25 Motor Set 	30015975	Noiseless Roller 	04990006	Drive Belt (100 m) 	30006883
		New Delac Roller (8 pieces per strip) 	00210027	Belt Joint 	04990009
End Side Pulley 	04990015	Pilot Roller 	04990007	Belt Joint Cover 	04990010
Motor Side Pulley 	04990016	Joint Plate 	04990011	OT Splice 	04990020
				Splice Pin 	30009334

* Progress 50/80 motor is the same one.
Please use New Delac Roller over 50 kg (110 lb).