

TOSO eco

ROLLER BLIND & CURTAIN RAIL



RTJ2 - Fabric : Dim Out DR 08-90-Black

ROLLER BLIND CHAIN SYTEM



- Roll Blind Manual Type Chain/Rantai
- Cocok digunakan untuk Perumahan, Perkantoran, dan Hotel
- Simple dan Fungsional
- Tersedia berbagai macam pilihan kain

FITUR ROLL BLIND

Pengoperasian Ringan dan Lancar.

Roll blind dioperasikan dengan Chain Plastik atau Metal brass

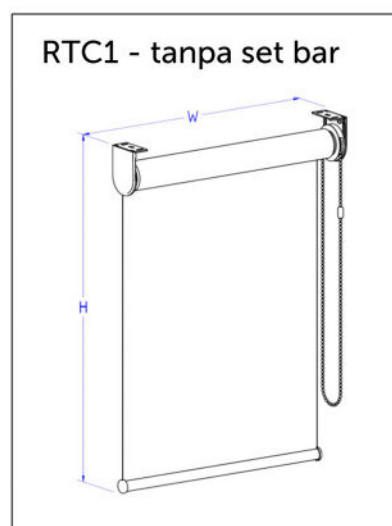
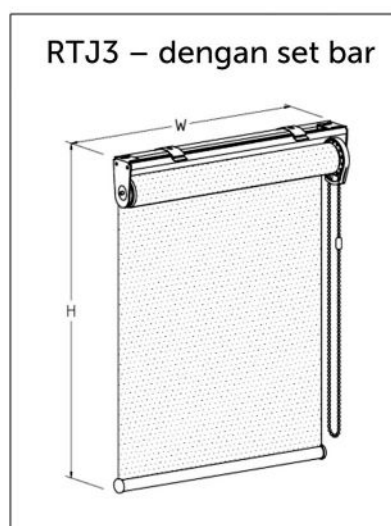
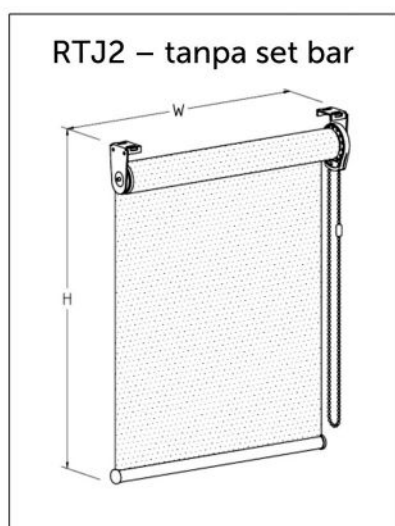

		RTJ2/RTJ3	RTC1
Maksimum berat kain		3.0 Kg	5.0 Kg
Kapasitas produk	Lebar produk	300 s/d 2.000mm	300 s/d 2.200mm
	Tinggi produk	400 s/d 3.000mm	400 s/d 4.000mm
	Ratio (Lebar : Tinggi)	1:3 (maks)	1:3 (maks)

Catatan : Kapasitas produk (Lebar, Tinggi, ratio/Perbandingan) bisa berbeda tergantung dari berat ,dan tebal kain Roll Blind

Rail Gorden

NEOLITE



- Rail Gorden manual
- Cocok digunakan untuk perumahan, hotel, dan Villa
- Dilengkapi dengan roda khusus yang bisa diperasikan dengan halus dan lancar
- Telah lulus test lebih dari 10.000 kali buka / tutup.
- Dapat digunakan sebagai rel penyekat untuk kebutuhan rumah sakit

Motorized Roll Blind



- o Roll Blind Motorized dengan Built in Receiver
- o Pengoperasian dengan Remote atau Switch Dinding
- o Tersedia berbagai macam pilihan kain

Kapasitas Produk

Tube Φ 55 mm	
	Tipe Standar
Lebar	750 ~ 2000 mm
Tinggi	4000 mm
Berat Maksimum	5 kg - per unit

Tube Φ 65 mm	
	Tipe Standar
Lebar	750 ~ 2400 mm
Tinggi	5000 mm
Berat Maksimum	8 kg - per unit

* Ukuran maksimum dapat berubah tergantung lebar, berat dan tebal kain roll blind

TOSO eco

Spesifikasi Motor tipe E5MRSA 10/26

Tubular motor Built in Receiver	
Nominal Torque	: 10 Nm
Nominal Speed	: 26 rpm
Maximum no. of Turn in One Direction	: 45
Nominal Supply Voltage/Frequency	: 230 V/50 Hz
Power consumption at nominal speed	: 145 watts
Rated Current	: 0.64 Ampere
Thermal protector trips	: 4 minute (after motor running)
Working Temperature	: -10 °C ~ 50 °C
Protection Index	: IP 44
Noice level	: 42 dBA

Switch & Remote



Switch Wireless
1 channel (Max 20 motors)
Size: 86 x 86 x 11,7 mm



Remote
15 channel
Size: 130 x 45 x 11,5 mm

- Input : 3v Battery CR 2430
- Transmission Distance : Open Space – 200 ; Room - 20 M
- Frequency : 433,92 MHz

Basic Wiring Diagram

Switch / Remote Operation

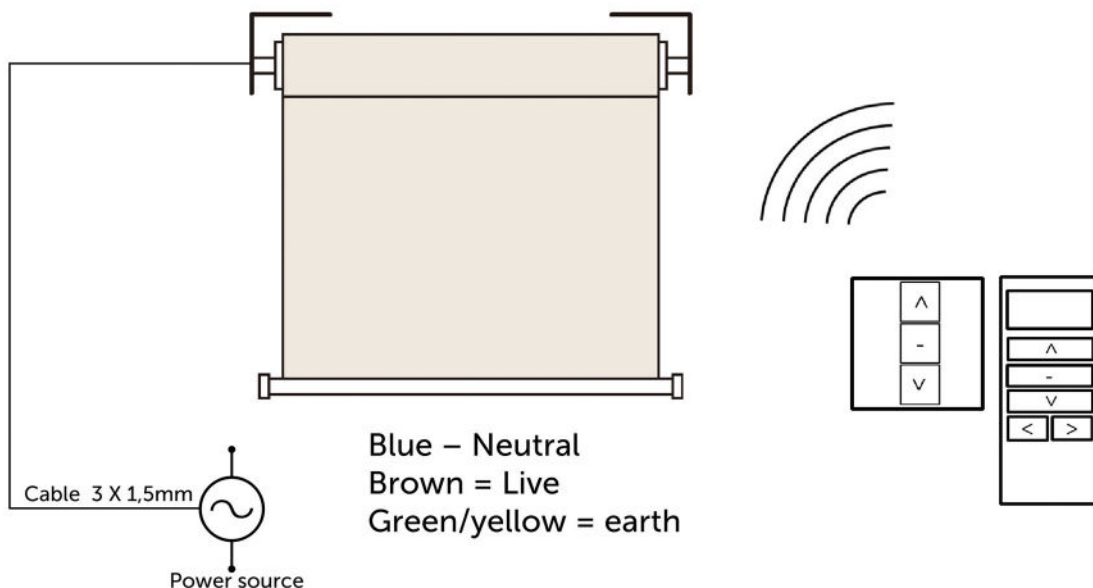

TOSO eco



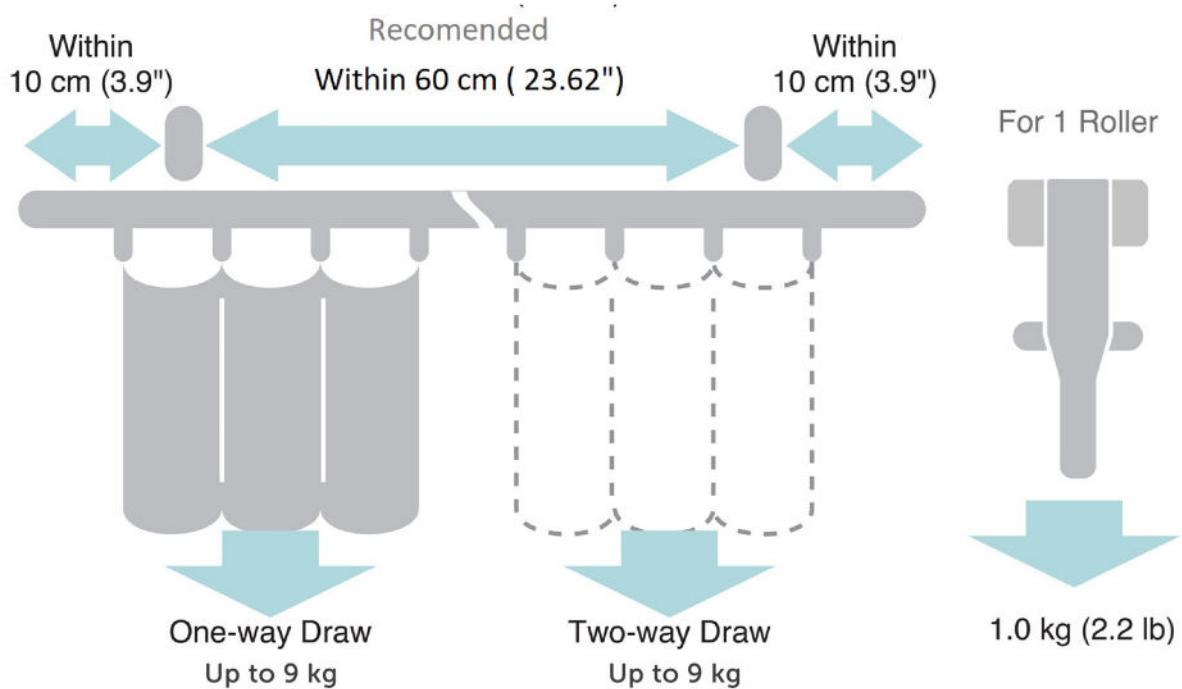

Fitur Neolite

- Berbekal pengalaman dan pengembangan lebih dari 40 tahun pada bidang manufaktur dan pemasangan rel gorden, memungkinkan kami dapat memproduksi Rail gorden berkualitas tinggi namun dengan harga yang terjangkau
- Desainnya compact namun tetap mampu menahan bobot gorden hingga 18 kg*
*untuk dua arah

Petunjuk Jarak Braket dan Kapasitas Roda

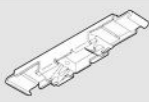
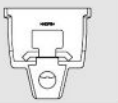

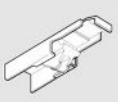
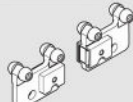
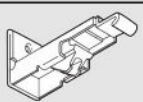
Komponen Neolite

Neolite Roller		Neolite Ceiling Double Bracket	
Neolite End Cap		Neolite Wall Double Bracket	
Neolite Ceiling Single Bracket		Neolite Magnet Carrier	
Neolite Wall Single Bracket		Neolite One way Magnet	

TOSO eco

ROMAN SHADE CHAIN SYTEM



- Roman Shade Manual Type Chain/Rantai
- Heavy Duty mampu sampai tinggi 5 meter
- Lancar, Simple, dan Fungsional
- Dapat dipadukan dengan kain gorden ataupun kain blind
- Suara Lembut dan tidak berisik
- Tersedia dengan banyak Pilihan kain

ROMAN SHADE TOSOeco dapat dipadukan dengan Curtain Fabric ataupun Roller Blinds Fabric



Lebar 3000mm Tinggi 2600mm Fabric SR-82-80
*Sample fabric dapat dilihat di catalog TOSOeco Fabric



Jumlah Loop = Swag,
Total diatas =6 swags

	Curtain Fabric	Roller Blinds Fabric
	SE1C	SE1R
Lebar produk	400 s/d 3.000mm	400 s/d 3.000mm
Tinggi produk	400 s/d 5.000mm	400 s/d 5.000mm
Maksimum Berat	6 Kg	6 Kg

TOSO eco

Showroom :

Jl. Tomang Raya No. 15, Jakarta - 11440, Indonesia

 (+62-21) 5601078 / 79 (Hunting)

 (+62-21) 5601083, 5601069

 +62 811-1223-776

 toso.eco@sumbersetia.com

 www.sumbersetia.com

Branch :

Jl. Ngemplak 30, Kompl. Ambengan Plaza Blok B No.21
Surabaya - Indonesia

 (+62-31) 5459331, 5451133 (Hunting)

 (+62-31) 5317145

 +62 813 3416 6689

 ssasby@sumbersetia.com